



8" - 10" Self-Priming Chopper Pumps

Materials of Construction:

- Casing/Housing/**
- Bearing Frame:** Ductile cast iron
- Impeller/Upper Cutter:** Cast steel, heat treated to minimum 60 Rockwell C Hardness
- Cutter Bar:** Alloy steel, heat treated to minimum Rockwell C-60
- Shaft:** Heat treated steel.
- Thrust Bearings:** Double-row angular contact ball
- Radial Bearings:** Spherical roller
- Lubrication:** ISO 46 hydraulic oil.
- Mechanical Seal:** Cartridge type, with silicon carbide or tungsten carbide faces.
- Flanges:** ANSI class 125 discharge, and class 150 suction
- Paint:** Epoxy.

DRAWINGS AND DIMENSIONS SUBJECT TO CHANGE WITHOUT NOTICE. DO NOT USE FOR CONSTRUCTION PURPOSES. CONTACT VAUGHAN FOR CERTIFIED CONSTRUCTION PRINTS.

ALL DIMENSIONS ARE IN INCHES UNLESS OTHERWISE NOTED.

DIRECT DRIVE

MODEL	A	B	C	D	E	F	G
SP8N	35 1/4	33 1/4	24 3/4	18 1/8	3	8	10
SP10R	35 1/4	33 1/4	24 3/4	16 1/4	3	10	12

MODEL	H	K	L	M	Q	R
SP8N	38 3/16	96	92	118 3/4	46	36
SP10R	38 3/16	96	92	118 3/4	46	36

BELT DRIVE

MODEL	A	B	D	E	F	G	J
SP8NB	35 1/4	33 1/4	18 1/8	3	8	10	54
SP10RB	35 1/4	33 1/4	16 1/4	3	10	12	54

MODEL	N	P	S	T	U	V
SP8NB	77 1/4	52	40	24 1/4	84	80
SP10RB	77 1/4	52	40	24 1/4	84	80

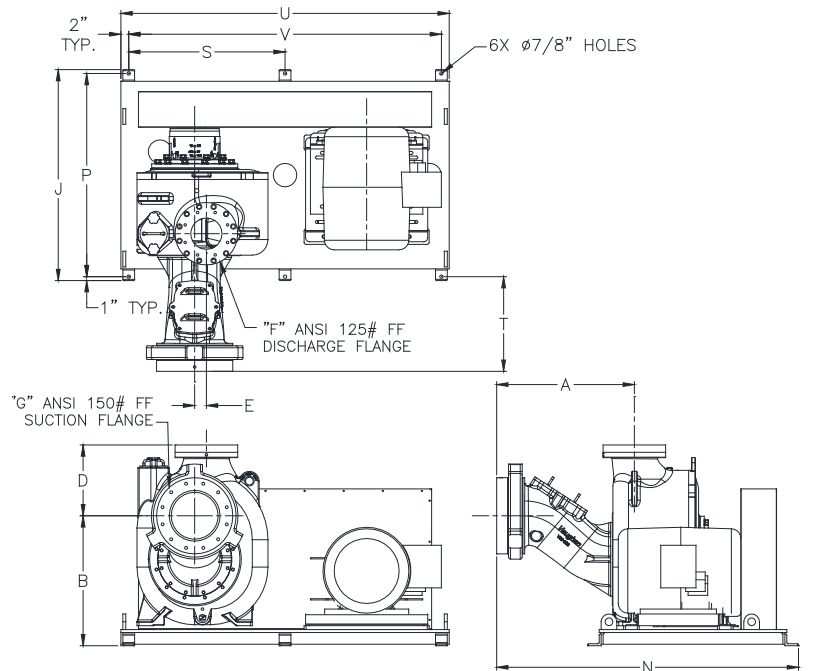
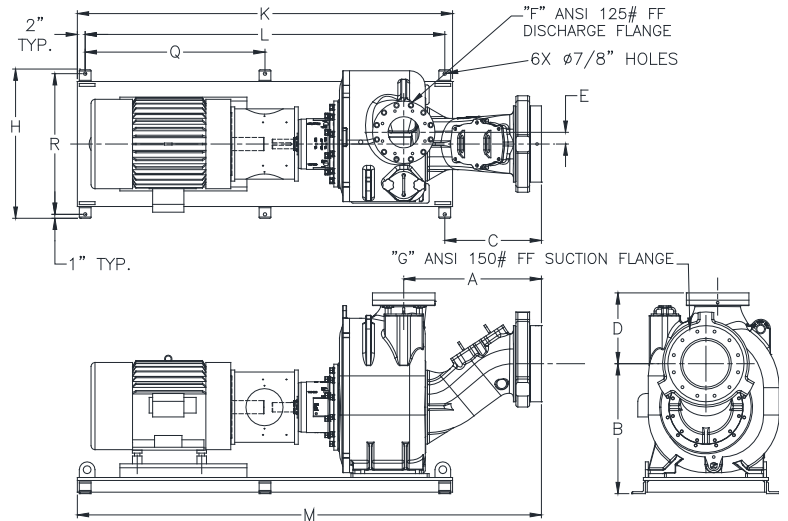

Vaughan Co., Inc.

364 Monte Elma Road
Montesano, WA 98563

Phone: 360-249-4042, FAX: 360-249-6155

E-mail: info@chopperpumps.com

CURRENT U.S. PATENTS: Nos. 7,125,221, 5,460,482; 5,460,483; 5,456,580; 5,256,032; 5,076,757; 4,840,384; 4,842,479.

CURRENT FOREIGN PATENTS: Nos. 2 371 834; 2 188 138; 1,290,981; 276224; 0 774 045.

OTHER PATENTS PENDING.

SPECIFICATIONS

SELF-PRIMING CHOPPER PUMPS

The self-priming chopper pump shall be a centrifugal pump specifically designed to pump waste solids at heavy consistencies without plugging or dewatering of the solids. Materials shall be chopped/macerated and conditioned by the pump as an integral part of the pumping action. The pump must have demonstrated the ability to chop through and pump high concentrations of solids such as plastics, heavy rags, grease and hair balls, wood, paper products and stringy materials without plugging, both in tests and field applications. Pump shall be manufactured by Vaughan Co., Inc.

DETAILS OF CONSTRUCTION

- A. Housing: Shall include Class 150 flanged inlet and Class 125 discharge flanges, an oversized cleanout and mounting feet. A 1/2"-NPT pressure tap shall be included on or near the discharge flange. The housing shall be ductile cast iron with all water passages to be smooth, and free of blowholes and imperfections for good flow characteristics.
- B. Casing, Back-plate and Wear-plate: The pump casing shall be of volute design, spiraling outward to the Class 125 flanged centerline discharge. Back-plate shall allow removal of pump components from outboard of the casing, and allow external adjustment of impeller-to-cutter bar clearance. Casing and back-plate shall be ductile cast iron with all water passages to be smooth, and free of blowholes and imperfections for good flow characteristics. Back-plate will include a replaceable Rockwell C 60 steel wear plate adjustable for 0.005-0.050" clearance to cut against the rotating impeller pump-out vanes for removing fiber and debris.
- C. Impeller: Shall be semi-open type with pump out vanes to reduce seal area pressure. Chopping of materials shall be accomplished by the action of the cupped and sharpened leading edges of the impeller blades moving across the cutter bar at the intake openings, with a maximum set clearance between the impeller and cutter bar of 0.015" - 0.025". Impeller shall be cast steel, heat treated to minimum Rockwell C 60 and dynamically balanced. The impeller shall be threaded to the shaft and shall have no axial adjustments and no set screws.
- D. Cutter Bar: Shall be recessed into the pump bowl and shall contain at least 2 shear bars extending diametrically across the intake opening to within 0.020" - 0.040" of the rotating external cutter tooth, for the purpose of preventing intake opening blockage and wrapping of debris at the shaft area. Chopper pumps utilizing individually mounted shear bars, and which do not have a rotating external cutter extending through to the opposite side of the shear bar, shall not be acceptable. Cutter bar shall be alloy steel heat-treated to minimum Rockwell C 60.
- E. Upper Cutter: Shall be bolted into the back pull-out adapter plate behind the impeller, designed to cut against the pump-out vanes and the impeller hub, reducing and removing stringy materials from the mechanical seal area. Upper cutter shall be cast steel, heat treated to minimum Rockwell C 60. The upper cutter teeth are positioned as closely as possible to the center of shaft rotation to minimize cutting torque and nuisance motor tripping. The ratio of upper cutter cutting diameter to shaft diameter in the upper cutter area of the pump shall be 3.6 or less.
- F. External Cutter: The external cutter shall be used to eliminate binding or build-up of stringy materials at the pump inlet. The external cutter shall consist of opposing cutter wings which shear against the outside surface of the shear bars and the anvil, an integral cast tooth which shears against the adjacent surface of the shear bars, and a hex head sufficiently sized for ease of removal. The external cutter shall be cast alloy steel and heat treated to a minimum Rockwell C 60.
- G. Pump Shafting: The pump shaft and impeller shall be supported by bearings. All shafting shall be heat treated alloy steel.
- H. Bearings: Shall be oil bath lubricated with ISO 46 hydraulic oil. Shaft thrust in both directions shall be taken up by two back-to-back mounted single-row angular contact ball bearings, mounted in an adjustable position thrust bearing cartridge to permit upper cutter to impeller adjustment. A single spherical roller radial bearing shall also be provided. L-10 bearing life shall be minimum 100,000 hours.
- I. Bearing Housing: Shall be ductile cast iron, and machined with piloted bearing fits for concentricity of all components. Viton® double lip seals riding on stainless steel shaft sleeves are to provide sealing at each end of the bearing housing.
- J. Seal: Mechanical Seal system *specifically designed to require no seal flush*: The mechanical seal shall be located immediately behind the impeller hub to eliminate the stuffing box and maximize the flushing available from the impeller pumpout vanes. The seal shall be a screw-in, cartridge-type mechanical seal with Viton O-rings and silicon carbide (or tungsten carbide) faces. This cartridge seal shall be a pre-assembled, pre-tested so that no seal settings or adjustments are required from the installer. Any springs used to push the seal faces together must be shielded from the fluid to be pumped. The cartridge shall also include a 17-4PH, heat-treated seal sleeve and a ductile iron seal gland.
- K. Inlet Manifold: The pump assembly shall be mounted horizontally with a Class 150 inlet flange, cleanout, 1/2" NPT suction pressure tap, drain connection and mounting feet.
- L. Shaft Coupling: Bearing housing and motor stool design is to provide accurate, self-aligning mounting for a C-flanged electric motor. Pump and motor coupling shall be T.B. Woods Sureflex elastomeric type.
- M. Optional Belt Drive: Adjustable brackets shall be used to support an over-head mounted motor. Sheaves and belts shall be properly sized for horsepower ratings, and all guards are to be supplied with the belt drive system.
- N. Stainless Steel Nameplates: Shall be attached to the pump giving the manufacturer's model and serial number, rated capacity, head, speed and all pertinent data.
- O. Drive motor: Shall be ____ HP, ____ RPM, ____ volts, ____ phase, ____ hertz, ____ service factor, foot and C-flange mounted, _____ enclosure. The motor shall be sized for non-overloading conditions.
- N. Surface Preparation: Solvent wash and a single coat of Tnemec 431 epoxy (except motor).
- O. *OPTIONAL* Premium Surface Preparation: Solvent wash, sandblast, and coat with minimum 30 MDFT Tnemec Perma-Shield PL Series 431 epoxy (except motor).