



## 3" - 6" S-SERIES SUBMERSIBLE RECIRCULATOR CHOPPER PUMPS

### Materials of Construction:

- Impeller/Upper Cutter/Cutter Bar/Cutter Nut:** ..... Cast Alloy Steel, heat treated to minimum Rockwell C 60.
- Casing/Bearing Housing/Guide Bracket/Elbow:** ..... Ductile Cast Iron.
- Mechanical Seal:** ..... Cartridge type, with silicon carbide (or tungsten carbide) faces and stainless steel sleeve.
- Flange:** ..... ANSI Class 125.
- Valve Assembly** ..... Ductile Cast Iron with stainless steel disc.
- Paint:** ..... Epoxy.

SEE THE S-SERIES SUBMERSIBLE PUMP SPECIFICATION FOR PUMP DIMENSIONS.

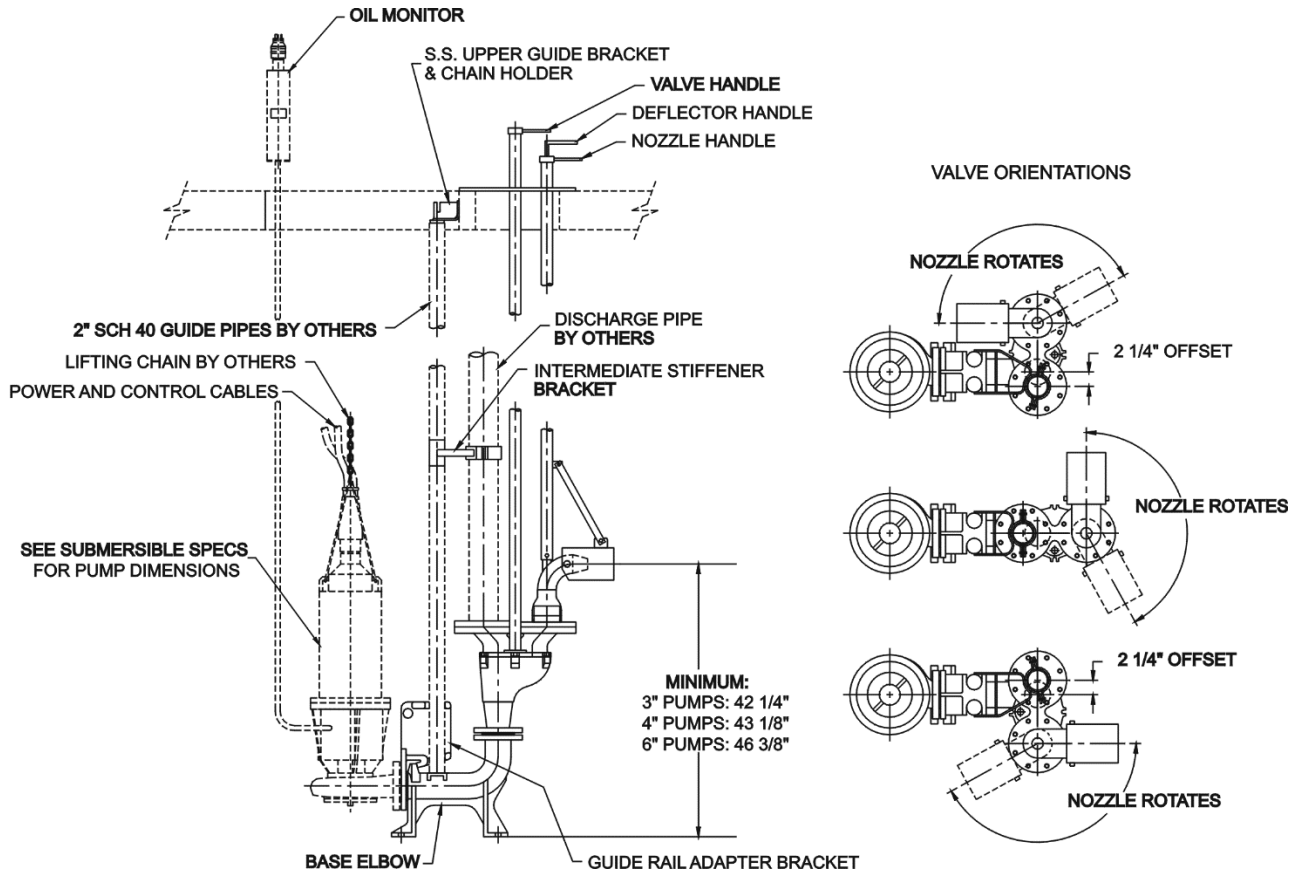

**VAUGHAN CO., INC.**  
 364 Monte Elma Road, Montesano, WA 98563  
 Phone: 1-360-249-4042 / Fax: 1-360-249-6155  
 Toll Free Phone (US only): 1-888-249-CHOP (2467)  
 Web Site: [www.chopperpumps.com](http://www.chopperpumps.com)  
 Company E-mail: [info@chopperpumps.com](mailto:info@chopperpumps.com)

**MADE IN THE  
USA**

For all current patents, see <http://www.chopperpumps.com/patents.htm>

## SPECIFICATIONS, 3"– 6" S-SERIES SUBMERSIBLE RECIRCULATOR CHOPPER PUMPS

The submersible recirculator chopper pump shall be specifically designed to mix and pump waste solids at heavy consistencies without plugging or dewatering of the solids. Materials shall be chopped/macerated and conditioned by the pump as an integral part of the pumping action. The pump must have demonstrated the ability to chop through and pump high concentrations of solids such as plastics, heavy rags, grease and hair balls, wood, paper products and stringy materials without plugging, both in tests and field applications. Pump shall be manufactured by Vaughan Co., Inc.

### DETAILS OF CONSTRUCTION

- A. Casing:** Shall be of volute design, spiraling outward to the Class 125 flanged centerline discharge. Casing shall be ductile cast iron with all water passages to be smooth, and free of blowholes and imperfections for good flow characteristics. Casing shall include a replaceable Rockwell C 60 alloy steel cutter to cut against the rotating impeller pump-out vanes for removing fiber and debris.
- B. Impeller:** Shall be semi-open type with pump out vanes to reduce seal area pressure. Chopping/maceration of materials shall be accomplished by the action of the cupped and sharpened leading edges of the impeller blades moving across the cutter bar at the intake openings, with a set clearance between the impeller and cutter bar of 0.015-0.025" cold. Impeller shall be cast alloy steel heat treated to minimum Rockwell C 60 and dynamically balanced. The impeller shall be keyed to the shaft and shall have no axial adjustments and no set screws.
- C. Cutter Bar Plate:** Shall be recessed into the pump bowl and shall contain at least 2 shear bars extending diametrically across the intake opening to within 0.010-0.030" of the rotating cutter nut tooth, for the purpose of preventing intake opening blockage and wrapping of debris at the shaft area. Chopper pumps utilizing individually mounted shear bars shall not be acceptable. Cutter bar shall be alloy steel heat-treated to minimum Rockwell C 60.
- D. Cutter Nut:** The impeller shall be secured to the shaft using a cutter nut, designed to cut stringy materials and prevent binding using a raised, rotating cutter tooth. The cutter nut shall be cast alloy steel heat treated to minimum Rockwell C 60.
- E. Upper Cutter:** Shall be threaded into the casing or back pull-out adapter plate behind the impeller, designed to cut against the pump-out vanes and the impeller hub, reducing and removing stringy materials from the mechanical seal area. Upper cutter shall be cast alloy steel heat treated to minimum Rockwell C 60. The upper cutter teeth are positioned as closely as possible to the center of shaft rotation to minimize cutting torque and nuisance motor tripping. The ratio of upper cutter cutting diameter to shaft diameter in the upper cutter area of the pump shall be 3.0 or less.
- F. Pump Shafting:** Shafting shall be heat treated alloy steel, with a minimum diameter of 1.5 inches in order to minimize deflection during solids chopping.
- G. Bearing Housing:** Shall be ductile cast iron, and machined with piloted bearing fits for concentricity of all components. Piloted motor mount shall securely align motor on top of bearing housing.
- H. Thrust Bearings:** Shaft thrust in both directions shall be taken up by two back-to-back mounted single-row angular contact ball bearings or a matched set of face to face tapered roller bearings with a minimum L-10 rated life of 100,000 hours. Overhang from the centerline of the lower thrust bearing to the seal faces shall be a maximum of 1.7". A third mechanical seal (two in motor) shall also be provided to isolate the bearings from the pumped media. The third seal, as well as the thrust bearings shall be oil bath lubricated in the bearing housing by ISO Grade 46 oil. Shaft overhang exceeding 1.7 inches from the center of the lowest thrust bearing to the seal faces shall be considered unacceptable.
- I. Pump Mechanical Seal:** The mechanical seal shall be located immediately behind the impeller hub to maximize the flushing available from the impeller pump-out vanes. The seal shall be a cartridge type mechanical seal with Viton O-rings and silicon carbide (or tungsten carbide) faces. This cartridge seal shall be pre-assembled and pre-tested so that no seal settings or adjustments are required from the installer. Any springs used to push the seal faces together must be shielded from the fluid to be pumped. The cartridge shall also include a 17-4PH, heat treated seal sleeve and a ductile cast iron seal gland.
- J. Automatic Oil Level Monitor:** An oil level switch shall be mounted at the top of the wet well, with a hose feeding down to the side of the bearing housing to monitor oil level and shut off the motor in event of low oil level. A relay shall be included for mounting in the motor control panel.
- K. Shaft Coupling:** The submersible motor shall be close coupled directly to the pump shaft using a solid sleeve coupling, which is keyed to both the pump and motor shafts. Slip clutches and shear pins between the shaft and the motor are considered unacceptable.
- L. Stainless Steel Nameplate:** The stainless steel nameplate giving the manufacturer's model and serial number, rated capacity, head, speed and all pertinent data shall be mounted to a larger stainless steel plaque. Warning tags and oil reservoir will be mounted to this same plaque. Plaque is to be fastened to wall or structure adjacent to pump.
- M. Submersible Motor:** The submersible motor shall be U/L or FM listed and suitable for Class I, Group C & D, Division I hazardous locations, rated at \_\_\_ HP, \_\_\_ RPM, \_\_\_ Volts, 50 or 60 Hertz and 3 phase, 1.15 service factor (1.0 for Continuous In-Air) with Class F insulation. Motor shall have tandem mechanical seals in oil bath and dual moisture sensing probes. Moisture probes must be connected to indicate water intrusion. The lower motor seal shall be exposed only to the lubricant in the pump bearing housing, with no exposure to the pumped media. Motor shall include two normally closed automatic resetting thermostats connected in series and embedded in adjoining phases. The thermostats must be connected per local, state, and/or the National Electric Code to maintain hazardous location rating and to disable motor starter if overheating occurs. Motor frame shall be cast iron, and all external hardware and shaft shall be stainless steel. Motor shall be sized for non-overloading conditions.
- N. Guide Rail System:** Provide a guide rail system consisting of two galvanized or stainless steel guide rails (by others), cast ductile iron pump guide bracket, discharge elbow with mounting feet and Class 125 flanges, 316 SS upper guide rail mounting bracket, and 316 SS intermediate guide rail stiffener bracket every 10 feet.
- O. Optional Spark Proof Guide Rail System:** Provide a non-sparking guide rail system consisting of two galvanized or stainless steel guide rails (by others), cast bronze pump guide bracket, cast ductile iron discharge elbow with mounting feet and Class 125 flanges, 316 SS upper guide rail mounting bracket, and 316 SS intermediate guide rail stiffener bracket every 10 feet. System design shall prevent spark ignition of explosive gases during pump installation and removal.
- P. Recirculation Nozzle Assembly:** The pump shall be fitted with a recirculation nozzle assembly to permit recirculation/conditioning of the pit contents prior to discharge. The recirculation nozzle shall be adjustable minimum 180° horizontally and 45° vertically. A valve assembly shall be connected to the pump discharge to adjust pump flow either to the nozzle or the pump discharge flange. Valve shall be ductile cast iron, with 316 SS valve disk. The operating levers shall be located above at a mounting plate for easy access.
- Q. Optional Automatic Valve Actuator:** An electrically operated valve actuator shall position the valve for pump out or mixed operation. A ball screw linear actuator shall be used to provide valve positioning. Unit shall operate on 110V or 220V AC, single-phase power with 25% duty cycle, and shall be capable of producing 500 pounds of actuation force, with a freewheeling feature to prevent over travel at the end of stroke. A capacitor for single phase-motor starting shall be included in the design. All components shall be housed in an enclosure suitable for outdoor operation. Includes a limit switch for indicating valve recirculation or discharge positions. External controls, housed in a separate control unit (by others), are required to indicate valve position
- R. Surface Preparation:** Degreased and coated with 5-8 MDFT epoxy. (except motor).
- S. OPTIONAL Surface Preparation:** Commercial sandblast (except motor), primed with 5-8 MDFT epoxy primer and finish coated with 5-8 MDFT epoxy (except motor).