



## 3"– 6" VERTICAL WET WELL CHOPPER PUMP

### Materials of Construction:

**Casing:** ..... Ductile Cast Iron.  
**Impeller/Cutter Bar/ Upper Cutter/Cutter Nut:** ..... Cast Alloy Steel, heat treated to minimum Rockwell C 60.  
**Mechanical Seal:** ..... Cartridge type with silicon carbide (or tungsten carbide) faces and stainless steel sleeve.  
**Thrust Bearings:** ..... Angular contact ball type or tapered roller type.  
**Radial Bearings:** ..... Ball type or spherical roller type.  
**Shaft:** ..... Heat treated alloy steel.  
**Lubrication:** ..... ISO Grade 46 oil.  
**Discharge Flange:** ..... ANSI Class 150  
**Mounting Plate:** ..... Carbon steel  
**Paint:** ..... Epoxy.

DRAWINGS AND DIMENSIONS SUBJECT TO CHANGE WITHOUT NOTICE. DO NOT USE FOR CONSTRUCTION PURPOSES. CONTACT VAUGHAN FOR CERTIFIED CONSTRUCTION PRINTS.

MODEL	A	B	C	D	E	F	G	H	J
V3F/V3G	10-3/8	18-5/8	24	20	10	3	4-3/4	1/2	1/2
V3L/V3M	11-7/8	20-1/4	24	20	10	3	3-9/16	1/2	1/2
V3P	13-7/8	23-3/8	24	20	10	3	2-11/16	1/2	1/2
V3V/V3W	11-1/4	20	24	20	8-7/8	3	3-5/8	1/2	3/4
V4K/V4L	13-7/8	23-1/2	24	20	10	4	3	1/2	1/2
V4S/V4T	16	26-5/8	30	20	10	4	5-1/2	1/2	1/2
V4V	20-3/8	34-3/8	40	26	13	4	5-5/8	3/4	3/4
V6U/V6X	17-1/2	31-5/8	36	24	12	6	6-7/8	1/2	1/2

### DIMENSIONS IN INCHES

HP	SPEED	FRAME	U*	V*
5	1170	215TC	26	11
	1750	184TC	23	10
7.5	1170	254TC	30	13
	1750	213TC	25	11
10	1170	256TC	32	13
	1750	215TC	26	11
15	1170	284TC	33	15
	1750	254TC	30	13
20	1170	286TC	34	15
	1750	256TC	32	13
25	1170	324TC	36	17
	1750	284TC	33	15
30	3510	256TC	32	13
	1170	326TC	38	17
40	1750	286TC	34	15
	3510	286TSC	34	15
50	1170	364TC	40	19
	1750	324TC	36	17
60	3510	324TSC	36	17
	1750	326TC	38	17
75	3510	326TSC	38	17
	1750	364TC	38	19
100	3510	364TSC	38	19
	1750	405TC	45	22
125	1750	444TC	52	25

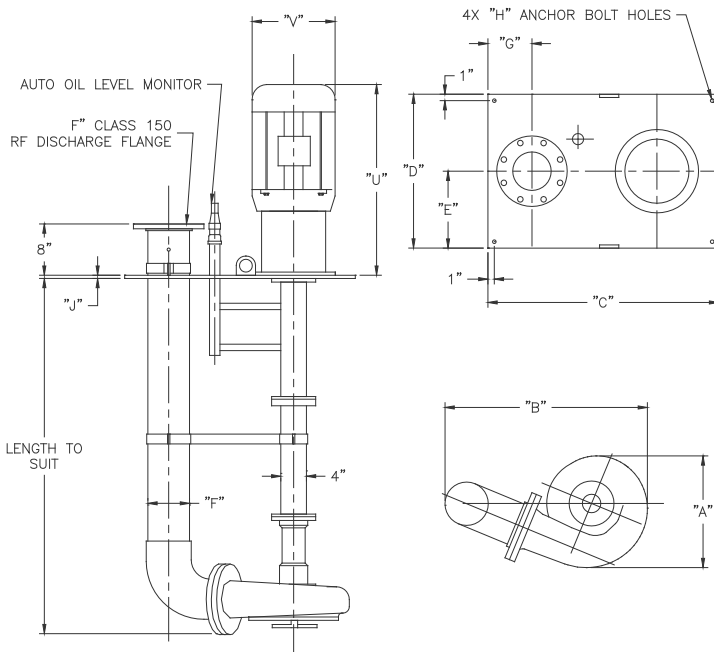

\*FOR REFERENCE ONLY. DIMENSIONS WILL VARY SLIGHTLY BY MOTOR MANUFACTURER.



**VAUGHAN CO., INC.**  
 364 Monte Elma Road, Montesano, WA 98563  
 Phone: 1-360-249-4042 / Fax: 1-360-249-6155  
 Toll Free Phone (US only): 1-888-249-CHOP (2467)  
 Web Site: [www.chopperpumps.com](http://www.chopperpumps.com)  
 Company E-mail: [info@chopperpumps.com](mailto:info@chopperpumps.com)

**MADE IN THE  
 USA**

For all current patents, see <http://www.chopperpumps.com/patents.htm>

## SPECIFICATIONS 3"- 6" VERTICAL WET WELL CHOPPER PUMPS

The Vendor shall furnish \_\_\_ vertical wet pit chopper pump(s) and all appurtenances as specified below. The pump(s) shall be specifically designed to pump waste solids at heavy consistencies. Materials shall be chopped and conditioned by the pump as an integral part of the pumping action. The pump must have demonstrated the ability to chop through and pump high concentrations of solids such as plastics, heavy rags, grease and hair balls, wood, paper products and stringy materials without plugging, both in tests and field applications.

### DETAILS OF CONSTRUCTION

- A. **Casing:** Shall be of volute or semi-volute design, spiraling outward to the Class 125 flanged discharge. Casing shall be ductile cast iron with all water passages to be smooth, and free of blowholes and imperfections for good flow characteristics. Casing shall include a replaceable Rockwell C 60 alloy steel cutter to cut against the rotating impeller pump-out vanes for removing fiber and debris.
- B. **Impeller:** Shall be semi-open type with pump out vanes to reduce seal area pressure. Chopping/maceration of materials shall be accomplished by the action of the cupped and sharpened leading edges of the impeller blades moving across the cutter bar at the intake openings, with a maximum set clearance between the impeller and cutter bar of 0.015-0.025" cold. Impeller shall be cast alloy steel heat treated to minimum Rockwell C 60 and dynamically balanced. The impeller shall be keyed to the shaft and shall have no axial adjustments and no set screws.
- C. **Cutter Bar Plate:** Shall be recessed into the pump bowl and shall contain at least 2 shear bars extending diametrically across the intake opening to within 0.010-0.030" of the rotating cutter nut tooth, for the purpose of preventing intake opening blockage and wrapping of debris at the shaft area. Chopper pumps utilizing individually mounted shear bars shall not be acceptable. Cutter bar shall be alloy steel heat-treated to minimum Rockwell C 60.
- D. **Cutter Nut:** The impeller shall be secured to the shaft using a cutter nut, designed to cut stringy materials and prevent binding using a raised, rotating cutter tooth. The cutter nut shall be cast alloy steel heat treated to minimum Rockwell C 60.
- E. **Upper Cutter:** Shall be threaded into the casing behind the impeller, designed to cut against the pump-out vanes and the impeller hub, reducing and removing stringy materials from the mechanical seal area. Upper cutter shall be cast alloy steel heat treated to minimum Rockwell C 60. The upper cutter teeth are positioned as closely as possible to the center of shaft rotation to minimize cutting torque and nuisance motor tripping. The ratio of upper cutter cutting diameter to shaft diameter in the upper cutter area of the pump shall be 3.0 or less.
- F. **Pump Shafting:** Shall be heat treated alloy steel. Upper shaft extension shall be turned, ground and polished. The shaft column shall be minimum 3-1/2" inch schedule 40 steel pipe welded to steel flanges and machined with piloted bearing fits for concentricity of all components. All support column tubes shall be leak tested. Distance between shaft bearings shall not exceed critical speed dimensions.
- G. **Pump Shaft Bearings:** Shall be oil bath lubricated by ISO Grade 46 oil, with the exception of the top bearing, which shall be greased packed. The bearings shall have a minimum L-10 life rated 100,000 hours. Shaft thrust shall be taken up by either a double row angular contact ball bearing, or two back-to-back mounted single row angular contact ball bearings, or two face to face mounted tapered roller bearings, which bear against a machined shoulder on one side and the seal sleeve on the other side. Overhang from the centerline of the lower thrust bearing to the seal faces shall be a maximum of 1.7", with a mechanical seal to isolate the bearings from the pumped media.
- H. **Pump Mechanical Seal:** The mechanical seal shall be located immediately behind the impeller hub to maximize the flushing available from the impeller pump-out vanes. The seal shall be a cartridge-type mechanical seal with Viton O-rings and silicon carbide (or tungsten carbide) faces. This cartridge seal shall be pre-assembled and pre-tested so that no seal settings or adjustments are required from the installer. Any springs used to push the seal faces together must be shielded from the fluid to be pumped. The cartridge shall also include a 17-4PH, heat-treated seal sleeve and a ductile cast iron seal gland.
- I. **Automatic Oil Level Monitor:** Shall be located above the mounting plate and be fitted with an internal oil level switch to monitor oil level and shut off the motor in event of low oil level. A relay shall be included for mounting in the motor control panel.
- J. **Pump Discharge Pipe:** The pump assembly shall be mounted vertically on a common steel base plate with a Class 150 discharge flange. An NPT pressure tap shall be located above the deck plate.
- K. **Shaft Coupling:** Shall be T.B. Woods Sureflex elastomeric type with a minimum 1.5 service factor based on the drive rated horsepower, and shall be protected with a guard meeting OSHA requirements.
- L. **Motor Stool:** Shall be a fabricated carbon steel weldment machined with piloted fits to positively align the C-flanged motor and pump shaft, with no adjustments.
- M. **Pump Base Plate:** Shall be fabricated carbon steel, 1/2" minimum thickness, and shall include lifting lugs.
- N. **Stainless Steel Nameplate:** Shall be attached to the pump giving the manufacturer's model and serial number, rated capacity, head, speed, and all pertinent data.
- O. **Motor Requirements:** Drive motor shall be \_\_\_ HP, \_\_\_ RPM, \_\_\_ volts, 3 phase, 60 hertz, 1.15 service factor, TEFC enclosure. The motor shall be sized for non-overloading conditions.
- P. **Surface Preparation:** Solvent wash and a single coat of Tnemec 431 epoxy (except motor).
- Q. **OPTIONAL Premium Surface Preparation:** Solvent wash, sandblast, and coat with minimum 30 MDFT Tnemec Perma-Shield PL Series 431 epoxy (except motor).