



## V8K Vertical Wet Well Chopper Pump

### Materials of Construction:

<b>Casing:</b> .....	Ductile Cast Iron.
<b>Impeller/Cutter Bar/Upper Cutter/Cutter Nose:</b> .....	Cast alloy steel, heat treated to minimum Rockwell C 60.
<b>Mechanical Seal:</b> .....	Cartridge type with silicon carbide (or tungsten carbide) faces and stainless steel sleeve.
<b>Thrust Bearings:</b> .....	Tapered roller bearings.
<b>Radial Bearings:</b> .....	Spherical roller bearing.
<b>Shaft:</b> .....	Heat treated alloy steel.
<b>Lubrication:</b> .....	ISO 46 hydraulic oil.
<b>Discharge Flange:</b> .....	ANSI Class150
<b>Paint:</b> .....	Epoxy

DRAWINGS AND DIMENSIONS SUBJECT TO CHANGE WITHOUT NOTICE. DO NOT USE FOR CONSTRUCTION PURPOSES.  
CONTACT VAUGHAN FOR CERTIFIED CONSTRUCTION PRINTS.

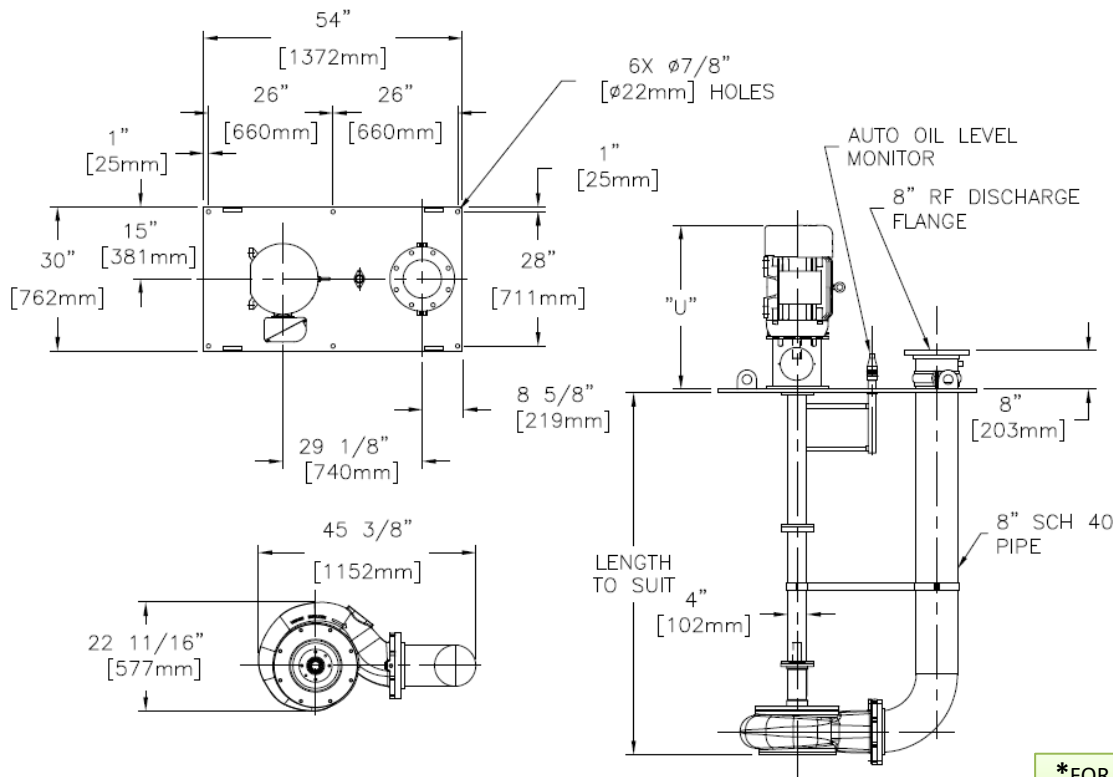

NEMA Frame	*U
254TC	28.90"
256TC	30.60"
284TC	32.35"
286TC	33.85"
324TC	37.40"
326TC	37.40"
364TC	39.70"
365TC	39.70"
405TC	45.85"

IEC Frame	*U
112M	620 mm
132S	685 mm
132M	725 mm
160M	800 mm
180M	860 mm
200L	950 mm
225S	1009 mm
225M	1034 mm

(1:2: SCALE) MODEL: V8K SPEC SHEET DWG. #120218 REV. 0 1/10/19

\*FOR REFERENCE ONLY.  
DIMENSION WILL VARY BY  
MOTOR MANUFACTURER.



### VAUGHAN CO., INC.

364 Monte Elma Road, Montesano, WA 98563  
Phone: 1-360-249-4042 / Fax: 1-360-249-6155  
Toll Free Phone (US only): 1-888-249-CHOP (2467)  
Web Site: [www.chopperpumps.com](http://www.chopperpumps.com)  
Company E-mail: [info@chopperpumps.com](mailto:info@chopperpumps.com)

For all current patents, see <http://www.chopperpumps.com/patents.htm>

**MADE IN THE  
USA**

## SPECIFICATION: V8K VERTICAL WET WELL CHOPPER PUMP

The vertical wet well chopper pump shall be specifically designed to pump waste solids at heavy consistencies. Materials shall be chopped and conditioned by the pump as an integral part of the pumping action. The pump must have demonstrated the ability to chop through and pump high concentrations of solids such as plastics, heavy rags, grease and hair balls, wood, paper products and stringy materials without plugging, both in tests and field applications.

### DETAILS OF CONSTRUCTION

- A. Casing and Backplate:** The pump casing shall be of volute design, spiraling outward to the ANSI CL 150 flanged discharge. Back pull-out design shall incorporate adjusting sleeves for accurate adjustment of impeller-to-cutter bar clearance. Casing & backplate shall be ductile cast iron with all water passages to be smooth, and free of blowholes and imperfections for good flow characteristics. Backplate shall include a replaceable Rockwell C60 alloy steel cutter adjustable for 0.005-0.050" (0.15-1.25 mm) clearance to cut against the rotating impeller pumpout vanes for removing fiber and debris.
- B. Impeller:** Shall be semi-open type with pump out vanes to reduce seal area pressure. Chopping/maceration of materials shall be accomplished by the action of the cupped and sharpened leading edges of the impeller blades moving across the cutter bar at the intake openings, with a set clearance between the impeller and cutter bar of 0.015-0.025" (0.40-0.65 mm) cold. Impeller shall be cast alloy steel heat treated to minimum Rockwell C60 and dynamically balanced. The impeller shall be threaded to the shaft and shall have no axial adjustments independent of bearings and no set screws.
- C. Cutter Bar:** Shall be recessed into the pump bowl and shall contain at least 2 shear bars extending diametrically across the intake opening to within 0.025-0.040" (0.65-1.0 mm) of the rotating cutter nose, for the purpose of preventing intake opening blockage and wrapping of debris at the shaft area. Chopper pumps utilizing individually mounted shear bars shall not be acceptable. Cutter bar shall be alloy steel heat-treated to minimum Rockwell C60.
- D. Cutter Nose:** Designed to cut stringy materials and prevent binding using two opposing cutter edges that cut against the inside of the cutter bar fingers. The cutter nose shall be alloy steel heat treated to minimum Rockwell C60.
- E. Upper Cutter:** Shall be threaded into the casing behind the impeller, designed to cut against the pump-out vanes and the impeller hub, reducing and removing stringy materials from the mechanical seal area. Upper cutter shall be cast alloy steel heat treated to minimum Rockwell C60. The upper cutter teeth are positioned as closely as possible to the center of shaft rotation to minimize cutting torque and nuisance motor tripping. The ratio of upper cutter cutting diameter to shaft diameter in the upper cutter area of the pump shall be 3.0 or less.
- F. Pump Shafting:** Shall be heat treated alloy steel. Upper shaft extension shall be turned, ground and polished. The shaft column shall be minimum 3-1/2" schedule 40 steel pipe welded to steel flanges and machined with piloted bearing fits for concentricity of all components. All support column tubes shall be leak tested. Distance between shaft bearings shall not exceed critical speed dimensions.
- G. Pump Shaft Bearings:** Shall be oil bath lubricated by ISO Grade 46 turbine oil, with the exception of the top bearing, which shall be grease packed. The bearings shall have a minimum L-10 life rated 100,000 hours. Shaft thrust in both directions shall be taken up by two face-to-face mounted tapered roller bearings, which bear against a machined shoulder on one side and the seal sleeve on the other side. Overhang from the centerline of the lower thrust bearing to the seal faces shall be a maximum of 1.7" (44 mm), with a mechanical seal to isolate the bearings from the pumped media.
- H. Pump Mechanical Seal:** The mechanical seal shall be located immediately behind the impeller hub to maximize the flushing available from the impeller pump-out vanes. The seal shall be a cartridge-type mechanical seal with Viton O-rings and silicon carbide (or tungsten carbide) faces. This cartridge seal shall be pre-assembled and pre-tested so that no seal settings or adjustments are required from the installer. Any springs used to push the seal faces together must be shielded from the fluid to be pumped. The cartridge shall also include a 17-4PH, heat-treated seal sleeve and a ductile cast iron seal gland.
- I. Automatic Oil Level Monitor:** Shall be located above the mounting plate and be fitted with an internal oil level switch to detect low oil level and shut off the motor in event of low oil level. A relay shall be included for mounting in the motor control panel.
- J. Pump Discharge Pipe:** The pump assembly shall be mounted vertically on a common steel base plate with an ANSI CL 150 rated discharge flange. A 1/4" NPT pressure tap shall be located above the deck plate.
- K. Shaft Coupling:** Shall be T.B. Woods Sureflex elastomeric type with a minimum 1.5 service factor based on the drive rated horsepower, and shall be protected with a guard meeting OSHA requirements.
- L. Motor Stool:** Shall be a fabricated carbon steel weldment machined with piloted fits to positively align the C or B5 flanged motor and pump shaft, with no adjustments.
- M. Pump Deck Plate:** Shall be fabricated carbon steel, 3/4" minimum thickness, and shall include lifting lugs.
- N. Stainless Steel Nameplate:** Shall be attached to the pump giving the manufacturer's model and serial number, rated capacity, head, speed and all pertinent data.
- O. Motor Requirements:** Drive motor shall be \_\_\_ HP (KW), \_\_\_ RPM, \_\_\_ volts, 3 phase, 60 (50) hertz, 1.15 service factor, C or B5 flange mounted, TEFC enclosure. The motor shall be sized for non-overloading conditions.
- P. Surface Preparation:** Solvent wash and a single coat of Tnemec 431 epoxy (except motor).
- Q. Optional Premium Surface Preparation** Solvent wash, sandblast, and coat with minimum 30 MDFT Tnemec Perma-Shield PL Series 431 epoxy (except motor).