

3"-6" SUBMERSIBLE SCREW CENTRIFUGAL PUMPS

Materials of Construction:

Impeller/Casing/Suction Cone/Back Pull-Out Plate: Ductile cast iron.
Insert Cutter:..... Alloy steel, heat treated to minimum Rockwell C 60.
Mechanical Seal: Cartridge type with silicon carbide (or tungsten carbide) faces and stainless steel sleeve.
Thrust Bearings:..... Back to back angular contact ball type or face to face tapered roller
Shaft: Heat treated alloy steel.
Lubrication: ISO Grade 46 oil.
Flanges: ANSI Class 125
Mounting Base: Ductile Cast Iron
Paint: Epoxy

DRAWINGS AND DIMENSIONS SUBJECT TO CHANGE WITHOUT NOTICE. DO NOT USE FOR CONSTRUCTION PURPOSES. CONTACT VAUGHAN FOR CERTIFIED CONSTRUCTION PRINTS

DIMENSIONS IN INCHES

MODEL	A	B	C	D	E	F	G	H	J	K	L	P
SSC3DS	14	7	27-1/4	7-3/4	8	23-1/2	3	21	9-1/2	6-1/16	14	3
SSC4DH	16	7-3/8	29-1/4	7-3/4	8	25	4	22-1/2	9-7/8	6-7/16	16	4
SSC6EM	20-1/2	9-1/2	35	9-3/4	8	29-1/2	6	24-3/8	11	7-9/16	20	6*
SSC6ES	20-1/2	9-1/2	35	9-3/4	8	29-1/2	6	24-3/8	11	7-9/16	20	6*

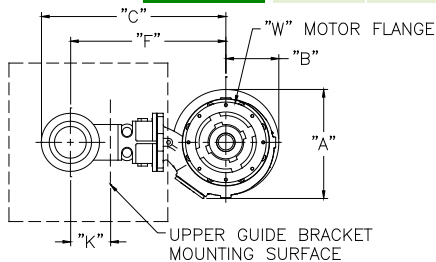

Note: 6" pump discharge can be connected to 5" or 6" flange.

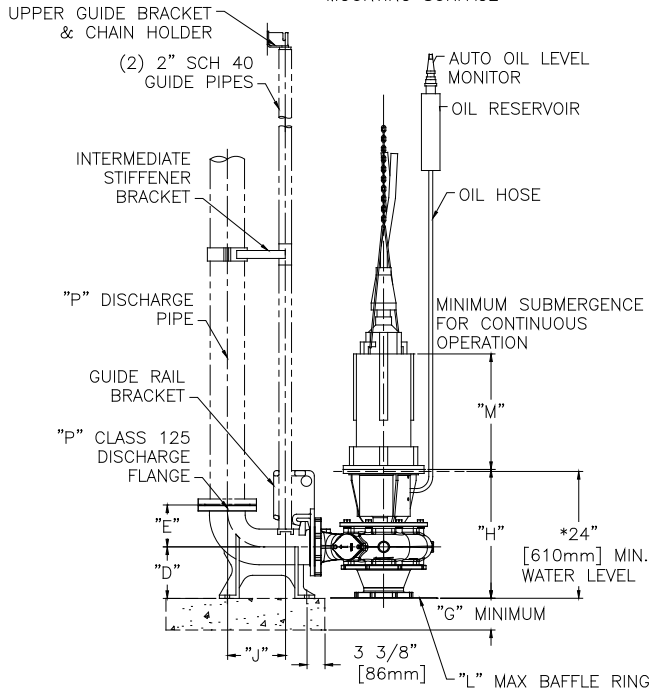

HP	SPEED	FRAME	M	W
7.5	1750	180TY	17-1/4	12-3/8
7.5	3510			
10	1750	210TY	21-7/8	15-1/4
10	3510			
15	3510	250TY	25	17
20	1750			
20	3510			
25	1750			
25	3510			
30	1750			
30	3510			
40	1750			
40	3510			

15 MINUTE IN-AIR FRAME SIZES ONLY

BAFFLE RING REQUIREMENT		
	MINIMUM FLOW	SIZE
SSC3DS	200 GPM	10" - 14"
SSC4DH	300 GPM	12" - 16"
SSC6EM	400 GPM	14" - 20"
SSC6ES	400 GPM	14" - 20"

*SSC3DS 12" SUBMERGENCE REQUIRED BELOW 600 GPM
 *SSC4DH 12" SUBMERGENCE REQUIRED BELOW 700 GPM
 *SSC6EM 12" SUBMERGENCE REQUIRED BELOW 1100 GPM
 *SSC6ES 12" SUBMERGENCE REQUIRED BELOW 1100 GPM



VAUGHAN CO., INC.
 364 Monte Elma Road, Montesano, WA 98563
 Phone: 1-360-249-4042 / Fax: 1-360-249-6155
 Toll Free Phone (US only): 1-888-249-CHOP (2467)
 Web Site: www.chopperpumps.com
 Company E-mail: info@chopperpumps.com

**MADE IN THE
USA**

For all current patents, see <http://www.chopperpumps.com/patents.htm>

SPECIFICATIONS: 3"-6" SUBMERSIBLE SCREW CENTRIFUGAL PUMPS

The Vendor shall furnish (___) submersible, screw-centrifugal pump(s) and all appurtenances as specified below. The pump(s) shall be of heavy-duty construction intended for services requiring reliable solids handling, gentle pumping action, high efficiency, and low NSPHR. Pump shall be manufactured by Vaughan Co., Inc.

DETAILS OF CONSTRUCTION

- A. Casing and Back Pull-Out Plate:** The pump casing shall be of volute design, spiraling outward to the Class 125 flanged centerline discharge. Casing & backplate shall be ductile cast iron with all water passages to be smooth, and free of blowholes and imperfections for good flow characteristics. Back pull-out design shall incorporate adjusting sleeves for accurate adjustment of impeller-to-suction cone clearance.
- B. Inlet Suction Cone:** The inlet suction cone shall be ductile cast iron with all water passages to be smooth, and free of blowholes and imperfections for good flow characteristics. The suction cone shall incorporate a spiral groove to channel fiber into the casing that would otherwise bind between the impeller OD and the inlet cone ID. The clearance of the impeller to the cone shall be externally adjustable without requiring pump or piping disassembly or special tools. A baffle ring will be provided when required to prevent vortexing.
- C. Impeller:** Shall be open channel, screw-centrifugal. The impeller shall be ductile cast iron and shall be dynamically balanced. The single-passage impeller shall combine the action of a positive displacement screw and a single-vane centrifugal impeller.
- D. Backplate Insert Cutter:** Shall be fitted into the back plate behind the impeller, designed to cut against a cutter in the impeller hub, reducing and removing stringy materials from the mechanical seal area. Insert cutters shall be alloy steel heat treat hardened to minimum Rockwell C 60.
- E. Impeller Hub Cutter:** Shall be alloy steel hardened to minimum Rockwell C 60 and fitted into the impeller hub (except 3" model).
- F. Pump Shafting:** Shafting shall be heat treated alloy steel supported by bearings.
- G. Pump Mechanical Seal:** The mechanical seal shall be located immediately behind the impeller hub to maximize the flushing available from the impeller. The seal shall be a cartridge-type mechanical seal with Viton O-rings and silicon carbide (or tungsten carbide) faces. This cartridge seal shall be pre-assembled and pre-tested so that no seal settings or adjustments are required from the installer. Any springs used to push the seal faces together must be shielded from the fluid to be pumped. The cartridge shall also include a 17-4PH, heat-treated seal sleeve and a ductile cast iron seal gland.
- H. Thrust Bearings:** Shaft thrust in both directions shall be taken up by two back-to-back mounted single-row angular contact ball bearings or two face to face mounted tapered roller bearings. Overhang from the centerline of the lower thrust bearing to the seal faces shall be a maximum of 1.7". Bearings shall be rated with a minimum L-10 bearing life of 100,000 hours at any acceptable operating point on the performance curve. The pump mechanical seal shall isolate the bearings from the pumped media.
- I. Bearing Housing:** Shall be ductile cast iron, and machined with piloted bearing fits for concentricity of all components. Piloted motor mount shall firmly align motor on top of bearing housing. Bearing housing shall be oil filled with ISO Grade 46 oil to provide lubrication for the pump mechanical seal and bearings.
- J. Automatic Oil Level Monitor:** An oil level float switch shall be mounted in a reservoir at the top of the wet well, with a hose feeding down to the side of the bearing housing to monitor oil level and shut off the motor in event of low oil level. A relay shall be included for mounting in the motor control panel.
- K. Shaft Coupling:** The submersible motor shall be coupled directly to the pump shaft using a solid sleeve coupling, which is keyed to both the pump and motor shafts.
- L. Stainless Steel Nameplate:** Shall be attached to the pump giving the manufacturer's model and serial number, rated capacity, head, speed and all pertinent data.
- M. Submersible Motor:** The submersible motor shall be U/L and CSA listed and suitable for Class I, Group C & D, Division I hazardous locations, rated at ___ HP, ___ RPM, ___ Volts, 60 Hertz and 3 phase, 1.15 service factor (1.0 for Continuous In-Air) with Class F insulation. Motor shall have tandem mechanical seals in oil bath and dual moisture sensing probes. Moisture probes must be connected to indicate water intrusion. The lower motor seal shall be exposed only to the lubricant in the pump bearing housing, with no exposure to the pumped media. Motor shall include two normally closed automatic resetting thermostats connected in series and embedded in adjoining phases. The thermostats must be connected per local, state, and/or the National Electric Code to maintain hazardous location rating and to disable motor starter if overheating occurs. Motor frame shall be cast iron, and all external hardware and shaft shall be stainless steel.
- N. Guide Rail System:** Provide a guide rail system consisting of two galvanized or stainless steel guide rails (by others), cast ductile iron pump guide bracket, cast ductile discharge elbow with mounting feet and Class 125 flanges, 316 stainless steel upper guide rail mounting bracket, and 316 stainless steel intermediate guide rail stiffener bracket every 10 feet.
- O. Non-Sparking Guide Rail System:** Provide a non-sparking guide rail system consisting of two galvanized or stainless steel guide rails (by others), cast bronze pump guide bracket, cast ductile iron discharge elbow with mounting feet and Class 125 flanges, 316 stainless steel upper guide rail mounting bracket, and 316 stainless steel intermediate guide rail stiffener bracket every 10 feet. System design shall prevent spark ignition of explosive gases during pump installation and removal.
- P. Surface Preparation:** Solvent wash and a single coat of Tnemec 431 epoxy (except motor).
- Q. OPTIONAL Premium Surface Preparation:** Solvent wash, sandblast, and coat with minimum 30 MDFT Tnemec Perma-Shield PL Series 431 epoxy (except motor).