

Materials of Construction:

- Casing:** Carbon Steel
Propeller:..... Cast alloy steel, heat treated to minimum Rockwell C 60.
Upper Cutter: Cast alloy steel, heat treated to minimum Rockwell C 60.
Mechanical Seal: Cartridge type with silicon carbide (or tungsten carbide) faces and stainless steel sleeve.
Thrust Bearings:..... Back-to-back angular contact ball type.
Radial Bearings:..... Ball type.
Shaft:..... Heat treated alloy steel.
Lubrication:..... ISO Grade 46 oil.
Mounting Plate:..... Carbon steel.
Paint:..... Epoxy.

DRAWINGS AND DIMENSIONS SUBJECT TO CHANGE WITHOUT NOTICE. DO NOT USE FOR CONSTRUCTION PURPOSES. CONTACT VAUGHAN FOR CERTIFIED CONSTRUCTION PRINTS.

GEAR DRIVE

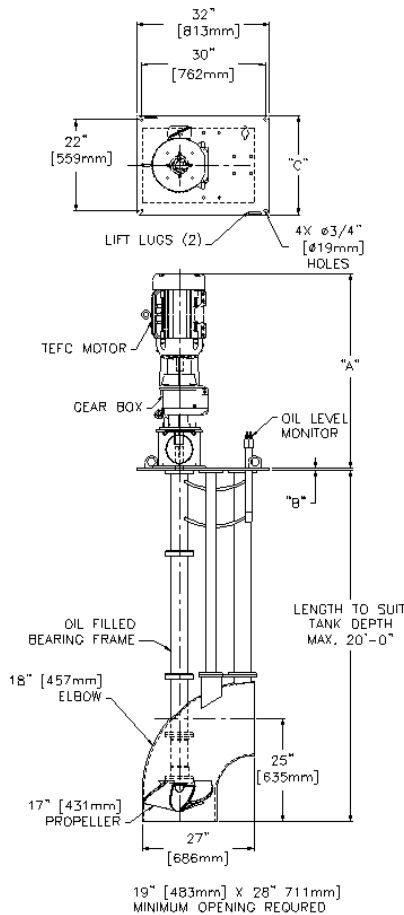

Belt Drive Pumps

	A	B	C	D
7.5 HP	21-1/2	3/4	24	22
10 HP	23	3/4	24	22
15 HP	26-1/4	3/4	24	22
20 HP	28	3/4	24	22
25 HP	30	1	32	30
30 HP	30-1/2	1	32	30

Gear Drive Pumps

	A	B	C
5 HP	35-7/8	3/4	24
7.5 HP	38-3/8	3/4	24
10 HP	39-7/8	3/4	24
15 HP	47 1/8	3/4	24
20 HP	44	3/4	24
25 HP	51-7/8	1	24
30 HP	35-5/8*	1	24

*30 HP IS GEAR MOTOR DRIVEN

BELT DRIVE

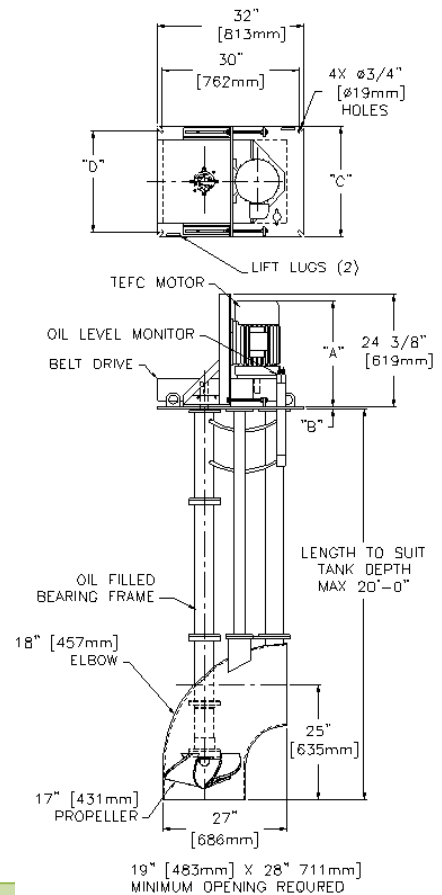

NOTE: Pumps over 12' long will have 1" thick deckplate.

SEE PAGE 2 FOR FLOWS AND MIXER SPEED



VAUGHAN CO., INC.
 364 Monte Elma Road, Montesano, WA 98563
 Phone: 1-360-249-4042 / Fax: 1-360-249-6155
 Toll Free Phone (US only): 1-888-249-CHOP (2467)
 Web Site: www.chopperpumps.com
 Company E-mail: info@chopperpumps.com
 For all current patents, please see <http://www.chopperpumps.com/patents.htm>

MADE IN THE
USA

SPECIFICATIONS: VERTICAL WET WELL TURBO-S MIXER

Drive	HP	Motor RPM	Mixer RPM	Prop Dia.	Flow (GPM)
Belt Drive	7.5	1765	384	17.0"	5,965
	10	1765	406	17.0"	6,310
	15	1765	477	17.0"	7,400
	20	1765	505	17.0"	7,900
	25	1765	569	17.0"	8,800
	30	1765	599	17.0"	9,300
Gear Box	5	1750	313	17.0"	4,830
	7.5	1765	383	17.0"	5,975
	10	1765	418	17.0"	6,500
	15	1765	478	17.0"	7,430
	20	1765	533	17.0"	8,365
	25	1765	546	17.0"	8,435
	30	1765	617	17.0"	9,600

- A. Casing:** 18-inch diameter carbon steel. Includes adjustable tool steel tip cutter.
- B. Propeller:** Cast alloy steel heat treated to minimum Rockwell C 60 hardness. Blades are axial flow design with large radius tips along leading edges. Propeller dynamically balanced.
- C. Upper Cutter:** Shall be threaded into the bearing housing behind the propeller, designed to cut against the propeller hub, reducing and removing stringy materials from the mechanical seal area. Upper cutter shall be cast alloy steel heat treated to minimum Rockwell C 60. The upper cutter teeth are positioned as closely as possible to the center of shaft rotation to minimize cutting torque and nuisance motor tripping. The ratio of upper cutter cutting diameter to shaft diameter in the upper cutter area of the mixer shall be 3.0 or less.
- D. Shafting:** Shall be heat treated alloy steel. Upper shaft extension shall be turned, ground and polished. The shaft column shall be minimum 4" inch O.D. precision steel tubing welded to steel flanges and machined with piloted bearing fits for concentricity of all components. All support column tubes shall be leak tested. Distance between shaft bearings shall not exceed critical speed dimensions.
- E. Shaft Ball Bearings:** Shall be oil bath lubricated by ISO Grade 46 oil, with the exception of the top bearing, which shall be grease packed. The bearings shall have a minimum L-10 life rated 100,000 hours. Shaft thrust shall be taken up by two back-to-back mounted single row angular contact ball bearings, which bear against a machined shoulder on one side and the seal sleeve on the other side. Overhang from the centerline of the lower thrust bearing to the seal faces shall be a maximum of 1.7", with a mechanical seal to isolate the bearings from the pumped media.
- F. Mechanical Seal:** The mechanical seal shall be located immediately behind the propeller hub to maximize the flushing available from the propeller vanes. The seal shall be a cartridge-type mechanical seal with Viton O-rings and silicon carbide (or tungsten carbide) faces. This cartridge seal shall be pre-assembled and pre-tested so that no seal settings or adjustments are required from the installer. Any springs used to push the seal faces together must be shielded from the fluid to be pumped. The cartridge shall also include a 17-4PH, heat-treated seal sleeve and a ductile cast iron seal gland.
- G. Automatic Oil Level Monitor:** Shall be located above the mounting plate and be fitted with an internal oil level switch to monitor oil level and shut off the motor in event of low oil level.
- H. Mounting Plate:** Shall be fabricated carbon steel, 3/4" or 1" minimum thickness, and shall include lifting lugs.
- I. Gear Box with Motor Requirements:**
- **Shaft Coupling:** Shall be T.B. Woods Sureflex elastomeric type with a minimum 1.5 service factor based on the drive rated horsepower, and shall be protected with a guard meeting OSHA requirements.
 - **Motor Stool:** Shall be a fabricated carbon steel weldment machined with piloted fits to positively align the gear box and pump shafts, with no adjustments.
 - **Gear Box:** shall be a helical inline type vertically mounted to the motor stool
 - **Motor Requirements:** Drive motor shall be ___ HP, 1765 RPM, ___ volts, 3 phase, 60 hertz, 1.15 service factor, TEFC enclosure. The motor shall be sized for non-overloading conditions.
- J. Belt Drive Requirements:**
- **Belt Drive:** includes adjustable motor mount, safety guard, belts and sheaves for ___ Mixer RPM
 - **Motor Requirements:** Drive motor shall be ___ HP, 1765 RPM, ___ volts, 3 phase, 60 hertz, 1.15 service factor, TEFC enclosure. The motor shall be sized for non-overloading conditions.
- K. Stainless Steel Nameplate:** Shall be attached to the pump giving the manufacturer's model and serial number, rated capacity, head, speed and all pertinent data.
- L. Surface Preparation:** Solvent wash and a single coat of Tnemec 431 epoxy (except motor).
- M. OPTIONAL Premium Surface Preparation:** Solvent wash, sandblast, and coat with minimum 30 MDFT Tnemec Perma-Shield PL Series 431 epoxy (except motor).