



ELECTRIC SUBMERSIBLE PUMPS SE SERIES

INSTALLATION, OPERATION AND MAINTENANCE INSTRUCTIONS

Pump Model: _____

Pump S/N: _____

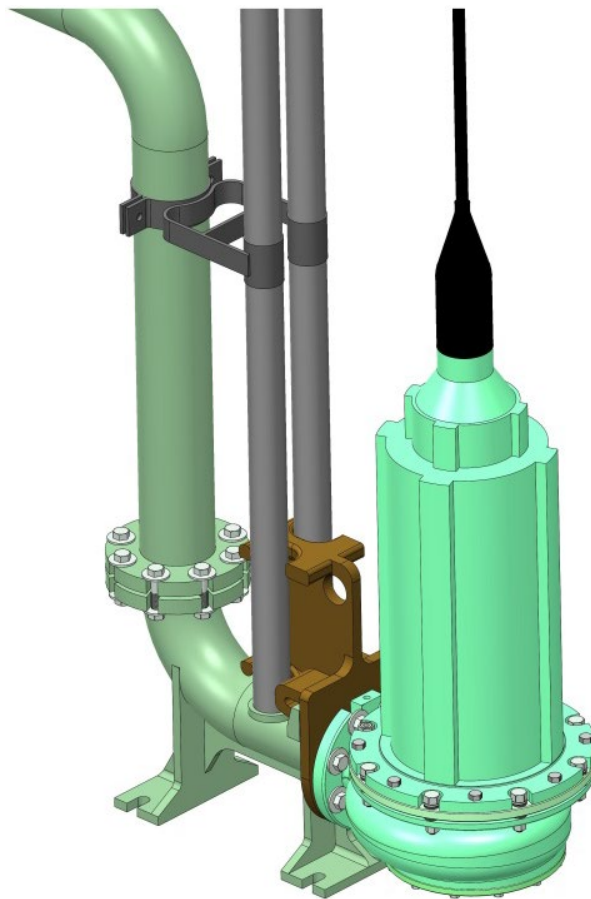

VAUGHAN CO., INC.

364 Monte Elma Road, Montesano, WA 98563
Phone: 1-360-249-4042 / Fax: 1-360-249-6155
Toll Free Phone (US only): 1-888-249-CHOP (2467)
Web Site: www.chopperpumps.com
Company E-mail: info@chopperpumps.com



TABLE OF CONTENTS

INSTALLATION, OPERATION, & MAINTENANCE INSTRUCTIONS

1. IMPORTANT SAFETY INFORMATION	Page 1
2. DESCRIPTION OF SUBMERSIBLE CHOPPER PUMP	Page 3
A. Description of Major Pump Components	
B. Proper Applications for Vaughan Chopper Pumps	
C. Uses of Vaughan Pumps that May Cause Trouble	
3. INSTALLATION INSTRUCTIONS	Page 7
A. Receipt Inspection	
B. Storage Considerations	
C. Mounting the Pump and Guiderail System in your Pit	
D. Piping	
E. Controls	
F. Submersible Motor	
4. PUMP STARTUP INSTRUCTIONS	Page 12
5. NORMAL OPERATION OF PUMP	Page 16
6. SHUTDOWN INSTRUCTIONS	Page 17
A. Manual Shutdown	
B. Automatic Shutdown	
C. Emergency Shutdown	
7. MAINTENANCE	Page 17
A. Routine Maintenance	
B. Corrective Maintenance	
8. TROUBLESHOOTING	Page 18
9. WARRANTY	Page 20

SECTION 1: IMPORTANT SAFETY INFORMATION

IMPORTANT INFORMATION FOR INSTALLERS OF THIS EQUIPMENT!

This equipment is intended for installation by technically qualified personnel. Failure to install it in compliance with national and local electrical codes, building codes and within Vaughan Co. recommendations may result in electrical shock, personal injury or death, fire hazard, unsatisfactory performance, and equipment failure. If further assistance is required contact your local representative or Vaughan Co. *Keep this manual in a safe location for future reference.*

⚠ DANGER Indicates a hazard, which, if not avoided, will result in death or serious injury.

⚠ WARNING Indicates a hazard, which, if not avoided, could result in death or serious injury.

⚠ CAUTION Indicates a hazard, which, if not avoided, may result in minor or moderate injury or damage to the equipment.

NOTICE Indicates special operation or maintenance information.

- Isolate the pump hydraulically and electrically before servicing or inspecting pump. Lock out both power source and isolation valves.
- This pump may handle dangerous or contaminated fluids. There are sharp corners, edges and pinch areas which can cause serious injury. Be careful; wear protective gloves whenever possible. If you cut yourself, seek medical help immediately to avoid serious infection.
- This pump may start automatically if wired to float switches or other equipment. Before inspecting or adjusting disconnect electrical power and lock out circuit breakers to pump motor and associated equipment. Duplex pumps with alternating relays must both be locked out; otherwise, the pump you are working on may not be isolated and could start as “the alternate”. Visually confirm that the pump has come to a complete stop before proceeding.
- Motors may be equipped with built-in thermal overloads to shut off the motors in the event the temperature gets too high (because of low voltage, poor ventilation, overloaded lines, etc.) These motors can restart automatically as the motor cools down. DO NOT work on the pump or motor without first disconnecting and locking out the power supply.
- Enter tanks or pits with extreme caution and only after an instrument check of the pit/tank has been completed to verify the absence of dangerous gases and the presence of safe levels of oxygen. Never enter a tank or pit without a safety harness and lifeline, and an air pack. Never enter the pit without rescue personnel standing by. Follow all national and local requirements for confined space entry.
- Keep all pit openings covered when not in use. In addition to the injuries from falling, pits may contain poisonous gases or liquids.
- Lift pump and motor by pump lifting bail only. Lifting by any other parts of this equipment is dangerous and may damage equipment. Inspect the lifting bail to be sure it is not damaged. Replace immediately if the bail is weakened in any way.
- Do not allow people under the pump assembly while it is being lifted.
- Pump components can be heavy. Proper methods of lifting must be employed to avoid physical injury and/or equipment damage. Steel toed shoes should be always worn.
- Do not allow liquid to be trapped in pump or piping between two closed valves. Always drain or vent the piping/pump between two closed valves. Failure to vent or drain could allow dangerous pressures to build causing rupture damage resulting in injury, death, and equipment damage.
- Never operate a pump with closed or blocked discharge valves. This will destroy the pump and could be dangerous to personnel.
- Do not operate this equipment unless safety guards or devices are in place and properly adjusted.
- Let the pump cool to ambient temperature before beginning work on it. A warm pump can contain compartments of pressurized fluid, which may vent violently during disassembly.

- Safety apparel to be worn when working on or adjusting pumps should include:
 - Heavy work gloves when handling parts with sharp edges, especially impellers.
 - Safety glasses (with side shields) for eye protection
 - Steel-toed shoes for foot protection when handling parts, heavy tools, etc.
 - Other personal protective equipment to protect against hazardous/toxic fluids and gases.
- Never apply heat to remove parts unless specifically directed to do so in overhaul instructions. Use of heat may cause an explosion due to trapped fluid, resulting in severe physical injury and property damage.
- As it is possible to run Vaughan pumps dry, for quality assurance or troubleshooting reasons, it is extremely important to ensure suction and discharge connections are always properly guarded to prevent anything (i.e., foreign objects or pump parts) from being thrown from the pump as a projectile. All pumps must be run with suction and discharge piping in place, or blind flanges installed on suction and discharge connections. Blind flanges should be vented to avoid pressure build-up. Note that cast rotating parts could break if metal to metal contact occurs while the pump is running dry.
- Shut pump off when adjusting fittings to avoid being sprayed with pumpage. Pumped materials may be hot, corrosive, poisonous, infectious, or otherwise dangerous to personnel.
- Pump motors are connected to high voltage. Allow only qualified electricians to service this electrical equipment only in accordance with the latest revision of the National Electrical Code and other applicable requirements.
- Make certain all personnel are clear of equipment before operating.
- This equipment may not meet explosion proof requirements for hazardous environments unless specifically ordered for this purpose. Introducing non-explosion proof equipment into a hazardous environment as defined by the National Electrical Code can cause a dangerous explosion.
- This pump uses oil which, if spilled, can cause a slipping hazard and danger to personnel.
- Keep hands, feet, and clothing away from moving machinery.
- Never clean, oil, adjust, or repair machinery while in motion.
- Keep electrical control panel area clear to avoid hazard to personnel. If a person should trip and fall into an open panel enclosure, serious electrical burns can result.
- Keep electrical control panel doors closed except to adjust or repair by a qualified electrician.
- Overheated pumps can cause severe burns and injury. If overheating of pump casing occurs:
 - 1) Shut down pump immediately.
 - 2) Wait for pump to cool to air temperature.
 - 3) Slowly and cautiously vent pump at drain plug.
 - 4) Troubleshoot cause of overheating.

Do Not Enter any Confined Manure Storage Areas Without Either:
 A self-contained air breathing apparatus (SCBA) and an approved harness/lifeline.
OR all of the following:

1. Testing the air for hydrogen sulfide, combustible gases or methane, and oxygen with dependable and reliable equipment, **AND**
2. Constant and adequate ventilation of fresh air, **AND**
3. An approved harness/lifeline on the person entering the pit with at least two people outside the pit who can pull the person out of the pit if necessary, **AND**
4. An approved pulley and tripod or other suitably strong lifting system that will make it possible to remove a limp body from the pit.

If there are any questions regarding the safe and proper methods for operating or servicing this pump, please contact Vaughan Company for assistance.

SECTION 2: DESCRIPTION OF VAUGHAN SUBMERSIBLE CHOPPER PUMP

The Vaughan submersible chopper pump is specifically designed for pumping trash laden material from wet pits in industrial and municipal plants. The pump can be used in the recirculating mode of operation to mix the pit before pumpout. An add-on recirculation valve mounted on the guiderail elbow must be obtained from Vaughan Co. to enable recirculation. Material is chopped up by the pump so that particle size is reduced, and downstream plugging problems are reduced.

A. DESCRIPTION OF MAJOR PUMP COMPONENTS

Note: Please refer to the illustrations in this manual which show the pump cross-section and the submersible chopper pump mounted on Vaughan's guiderail system. These pictures will help you understand this section more fully.

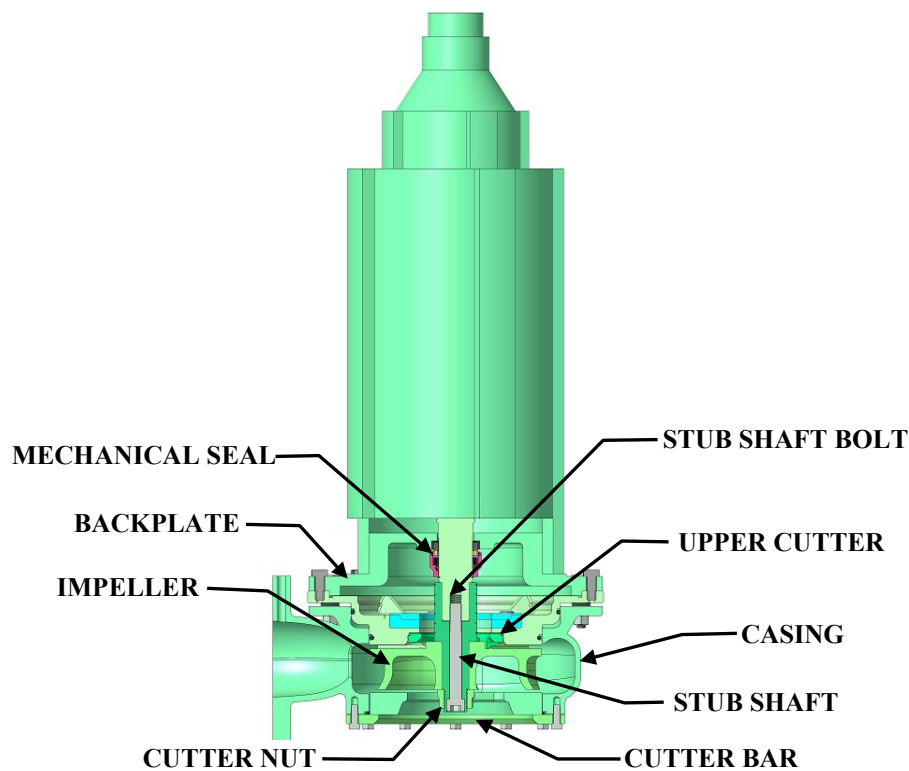

CHOPPER IMPELLER

The impeller on the Vaughan pump serves two purposes. First, it induces flow by drawing liquid into the pump and then accelerating it into the pump casing. Second, the impeller provides chopping capability for the pump. The leading edge of each impeller blade slopes forward to creating a knife edge so that as material enters the pump, it is caught and cut between impeller blade and the stationary shear bars at the inlet openings of the cutter bar plate. The impeller is held onto the pump shaft by a special "cutter nut".

CUTTER BAR PLATE

The cutter bar plate also serves two functions. First, it acts as a "wear plate" to seal pressure generated by the rotating impeller inside the pump. Second, the cutter bar provides two shear bars at the entrance to the pump so that material may be chopped by the pump impeller acting against these stationary shear bars.

CUTTER NUT

The cutter nut is a patented design that serves two purposes. First it secures the impeller to the shaft. Second the raised cutter tooth design prevents pump binding by cutting stringy materials that could otherwise wrap around the shaft and block the intake opening. The cutter nut is made of cast alloy steel heat treated to Rockwell C60. All 3-6" chopper pumps have a cutter nut.

EXTERNAL CUTTER (OPTIONAL ON 3-6" PUMPS)

The external cutter has opposing cutter wings that shear against the outside face of the cutter bar. It is used to prevent binding or the buildup of stringy materials at the pump inlet. The external tool is made of cast alloy steel heat treated to Rockwell C60 and is standard on Chopper pumps 8" and larger.

UPPER CUTTER

The upper cutter is located behind the impeller and cuts against the pumpout vanes and the impeller hub for the purpose of preventing stringy materials from wrapping in the mechanical seal area. The upper cutter is made of alloy steel heat treated to Rockwell C60.

DISINTEGRATOR TOOL (OPTIONAL)

The disintegrator tool, an option on 3"-6" submersible pumps, is an auxiliary cutter located below the pump inlet to help prevent blockage. Matted material which tends to block the opening to the pump can be cut up or knocked away by this tool until flow can resume into the pump. The disintegrator tool has the disadvantage; however, that material which tends to wrap – material like rags, hair, and nylon fiber can ball up on the tool and eventually block flow into the intake openings of the pump. (Vaughan Co. does not recommend the use of a disintegrator tool whenever you are pumping sewage or sewage sludge.) If the pump is installed with a disintegrator tool and suction blockage becomes a problem due to wrapping (problems usually show up as reduced flow or severe vibration), then the tool should be removed.

SEVERE DUTY LOWER SEAL IN SUBMERSIBLE MOTOR

The submersible motors utilized by Vaughan Co. are designed with two mechanical seals. One above (the upper seal) and one below (the lower seal) an oil chamber located below the rotor and stator. Normally these seals are John Crane Type 21 with carbon / ceramic faces. Vaughan Co. has replaced the lower seal with a high-quality metal bellows seal with tungsten carbide faces to better handle the trash-laden slurries that Vaughan pumps encounter.

GUIDERAIL SYSTEM

Vaughan submersible chopper pumps can be supplied with a simple stand or with a guiderail system. The guiderail system allows the pump to be withdrawn from the pit without the need for anyone to enter the pit. When mounted on the guiderail elbow the pump is supported completely by the pump casing discharge flange and adapter bracket. If the pump is to be mounted in a hazardous environment, you need to ensure a non-sparking aluminum bronze adapter bracket is used for the pump.

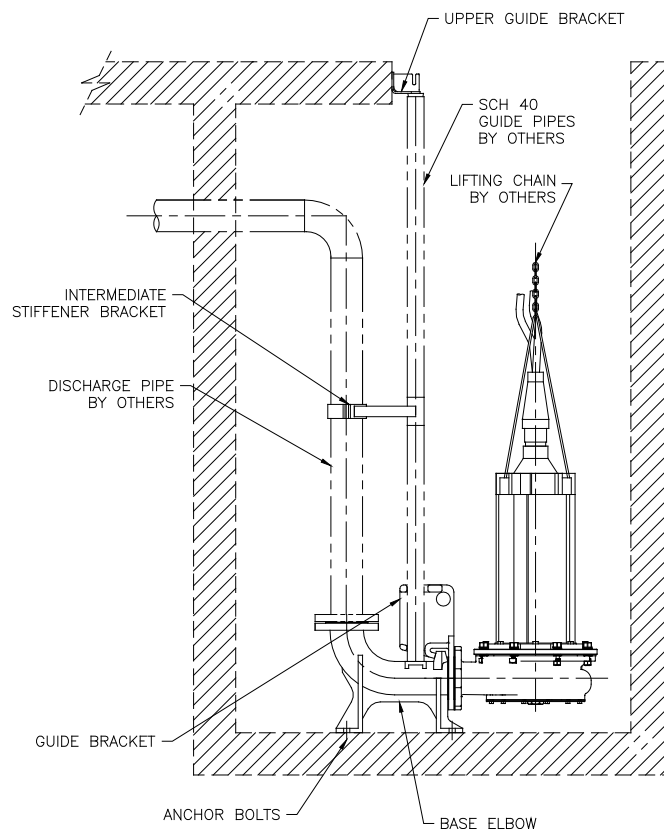

SUBMERSIBLE RECIRCULATION NOZZLE ASSEMBLY (OPTIONAL)

The Vaughan recirculation nozzle assembly consists of a 3-port valve with a recirculation nozzle mounted on the submersible pump discharge elbow and a deck plate to mount the handles for changing valve position and aiming the recirculation nozzle from above. See the illustration below.

The Vaughan recirculation nozzle assembly is specifically designed to mix the contents of a sump or scum pit by directing a stream of liquid into the sump or pit. This stream can be directed in various directions by adjusting the nozzle up or down and left or right using the nozzle deflector control handle and the nozzle control handle, respectively. This recirculation system allows the user to direct pump discharge back to the sump to mix liquid and debris in the pit to homogenize fluid prior to pumpout. Material is chopped up by the pump so that particle size is reduced, and downstream plugging problems are eliminated. Recirculation mixing is particularly helpful in pits where material either settles or else floats on the surface, such as sewage scum pits.

RECIRCULATION NOZZLE MAJOR COMPONENTS

NOZZLE

The Nozzle is located on a swivel joint to provide rotation in the horizontal plane. The nozzle handle is located above the deck plate and is used to steer the nozzle to the right or left. A sprocket and dog type locking mechanism are provided to secure the nozzle in proper direction.

DEFLECTOR

A deflector is located on the nozzle to adjust flow direction in the vertical plane. The deflector handle control rod slides up and down within the nozzle handle. A pin with retaining clip is used to secure the deflector at the proper angle.

VALVE

Recirculating nozzle assemblies have 3-way valves, which allow the operator to direct the flow out the discharge pipe or recirculate the flow within the sump.

DECKPLATE

The deck plate is custom made to suit each installation.

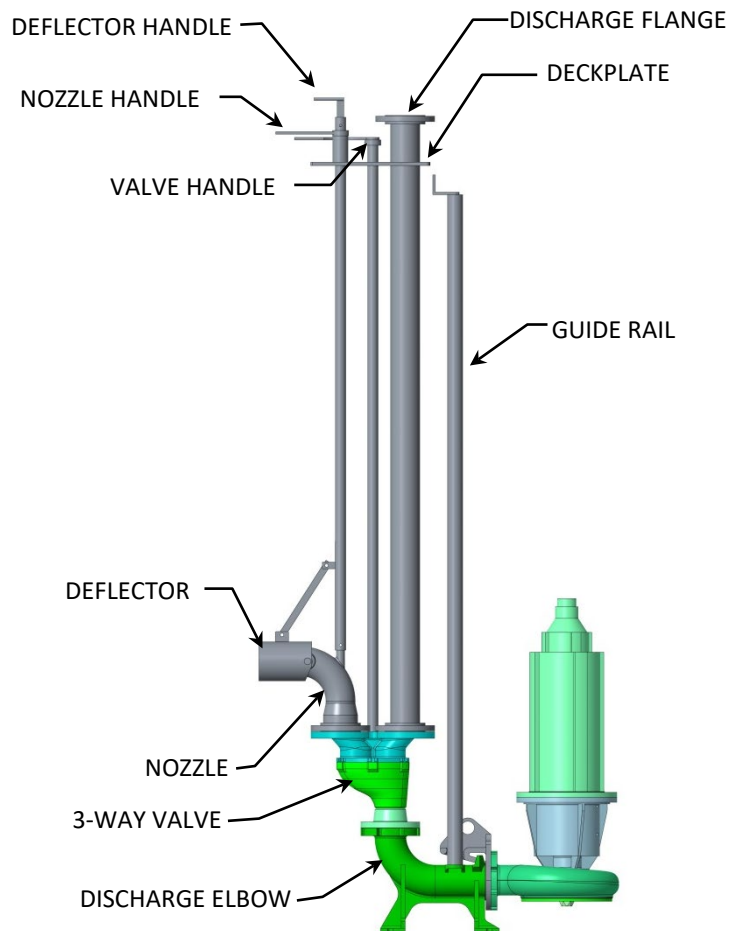

PROPER APPLICATIONS FOR VAUGHAN CHOPPER PUMPS

Vaughan Chopper Pumps are used for pumping liquid slurries contaminated with debris which can be chopped and mixed into the slurry. The benefit of this approach is that a more homogenous slurry is pumped, making some slurries pumpable (which might otherwise not be pumpable) and eliminating downstream plugging in other equipment. Also, screens located upstream of the pump may often be eliminated, cutting labor costs. Vaughan pumps are routinely used to pump the following slurries:

1. Sewage and sewage sludge
2. Fish waste.
3. Vegetable waste.
4. Mill scale.
5. Lead oxide and plastics in battery plants.
6. Aluminum chips from machining operations
7. Oil sludges in oil refineries.
8. Wood chips and paper waste.
9. Animal manures (dairy cow, pigs, and chicken).
10. Feathers mixed with blood and water in poultry plants.
11. Animal fat in rendering and hide processing plants.
12. Plastic debris.
13. Coal slurry

System design is very important in making any pump work successfully in pumping debris-laden slurries. There must be enough liquid so that material can be pumped. Also, liquid and material must be able to flow freely to the pump.

B. USES OF VAUGHAN PUMPS THAT MAY CAUSE TROUBLE

If the system is not designed correctly for proper handling of your material, or if the pump is incorrectly chosen for your system, the pump may not work to your satisfaction or the pump may experience early failures of seals or bearings. The following problems can be experienced:

1. When pumps vibrate, they are damaged.
2. A pump must be operated in the solid line areas of its pump performance curve. Operation in the dashed lines indicates vibration areas.
3. Operating a pump against very low backpressure damages pumps.
4. Operating a pump against too much backpressure damages pumps.
5. Chopper pump impellers with the largest number of blades are the most efficient, but they also provide the poorest solids handling. Added impeller blades block the inlet and cause increased binding on fiber during chopping. When pumping sewage and similar slurries, choose impellers with the *least* number of blades.
6. When pumping materials that float or settle in a pit, agitation and chopping with the pump are required before pit pumpout.
7. You cannot pump slurry that is too hot from an open pit. 65 deg C (149 deg F) is a reasonable upper limit for non-hazardous pits.
8. You must have a reliable electrical power supply for a pump to work properly. If you have too much of a voltage drop because of an undersized cable or transformer, the motor will not be able to provide full power to the pump and it will stall during chopping of debris.

SECTION 3: INSTALLATION INSTRUCTIONS

A. RECEIPT INSPECTION

Prior to shipment Vaughan pumps are carefully crated and inspected to ensure arrival at your plant in good condition. On receiving your pump, examine it carefully to assure that no damaged or broken parts have resulted from mishandling during shipping. Look for signs that the pump has been dropped, such as missing paint, dented flanges, cracked housings, or leaking oil. Turn the pump shaft by hand and verify that it turns over smoothly. If the shaft binds, look for debris between impeller and cutter bar. Otherwise, shaft binding could indicate damage. If damage has occurred, report to your carrier immediately, and consult your local Vaughan representative or call Vaughan Co. for advice

B. STORAGE CONSIDERATIONS

If equipment is to be stored for longer than two weeks, take the following action:

1. Coat exposed steel with a light layer of grease or protective spray-on lubricant to protect the equipment from corrosion.
2. Rotate the pump shaft 1-1/4 turn once each week to keep the bearings from sitting in one position for extended periods of time.
3. Avoid storing rotating equipment near other vibrating equipment. The vibrations can damage the ball bearings and result in premature failure once the equipment is started up.
4. Store rotating equipment in a clean, dry, heated area away from areas where it could be damaged from impact, smoke, dirt, vibration, corrosive fumes, or liquids, or from condensation inside the motor or pump. It is helpful to cover equipment with plastic.

C. MOUNTING THE PUMP AND GUIDERAIL SYSTEM IN YOUR PIT

The Vaughan submersible pump is heavy and will require a crane to lift it into position over your pit. Lifting the pump by the stainless-steel bale over the motor is the only recommended method for lifting.

⚠WARNING

Lifting provisions included with Vaughan pumps are rated for overhead lifting; however, do not allow people under Vaughan equipment during hoisting operations. Lift pump and motor with an adequately sized hoist, crane, or forklift. Consult the Vaughan Co. shipping department for weight of your equipment if you are in doubt.

If the pump is to be mounted on a guiderail system, the elbow will have to be bolted to the floor, and the guiderail upper bracket will have to be bolted either to your access cover frame or to some other structural member. The pump and elbow should be mounted at least 12" away from the nearest vertical wall in the pit. Expansion-type, cast-in place J-bolts, bolts mounted in sleeves, and epoxy anchoring systems are all acceptable anchoring means. **Please note that before startup, the pump should be located out of the pit where correct pump rotation may be verified.**

The chart on the following page will provide you with quantity, size, and location of anchor bolts for the base elbow or spool supplied with your pump.

The illustration on page 6 shows a typical submersible pump and guide rail system mounted in a pit. Normally the customer or the contractor will supply Schedule 40 galvanized or stainless-steel pipe for the actual guiderails. All other components in the guiderail system are available from Vaughan. When lifting a submersible pump on the guiderail system, use caution to avoid binding of the discharge bracket on the guiderails. Adjusting the angle on which the lifting cable pulls up on the lifting bail can relieve a great deal of the binding that might otherwise occur.

When lowering the pump into a pit on a guiderail system, it may be helpful to turn the pump on while the pump is mating to the elbow so that any debris may be flushed away from the mating surfaces, thus minimizing chances for leakage later. **(Never do this with 3510 RPM pumps.)** Vaughan submersible pumps use a metal-to-metal connection between pump and elbow for minimum mating problems over the life of the equipment.

Always take care to avoid damaging the motor cables and the epoxy joint where the cables enter the motor. If the cables are stretched, pulled, or crushed, they will be damaged.

VAUGHAN SUBMERSIBLE PUMP BASE ELBOW ANCHOR BOLT INFORMATION

3"–10" BASE ELBOWS

6"&12"–20" BASE SPOOLS

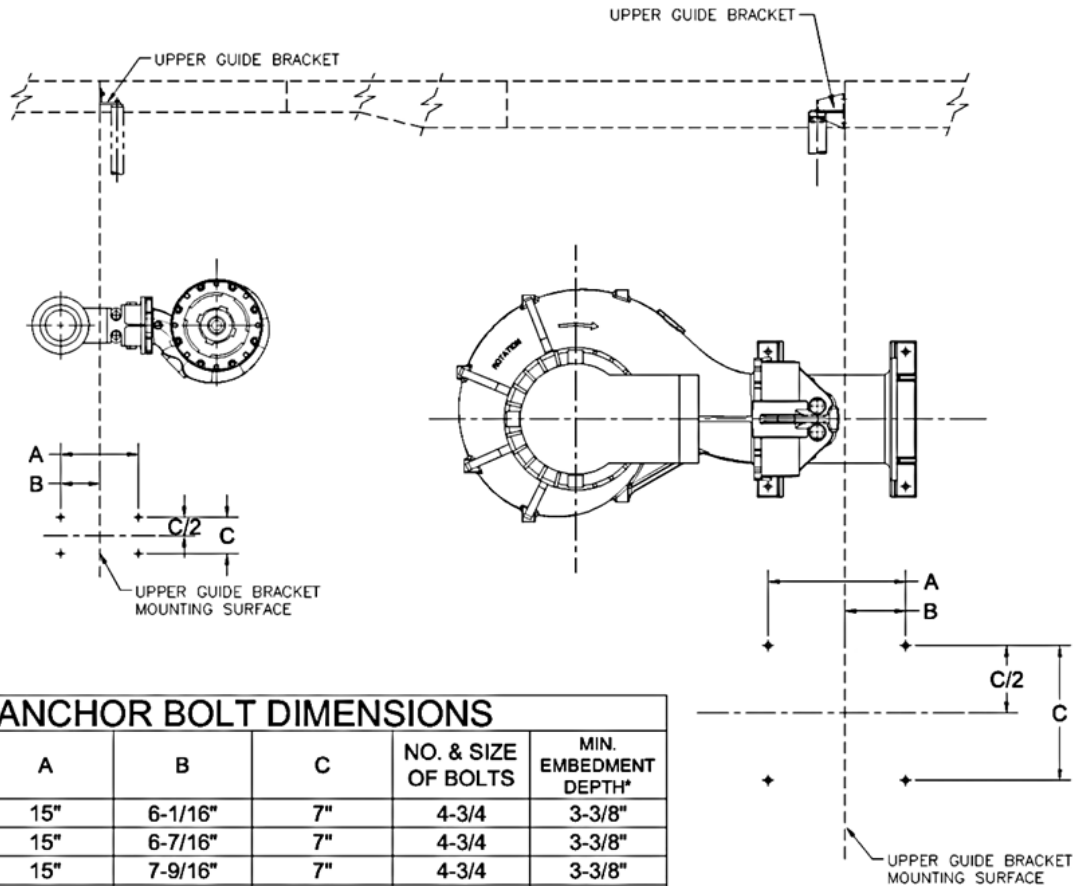

ANCHOR BOLT DIMENSIONS

BASE SIZE	A	B	C	NO. & SIZE OF BOLTS	MIN. EMBEDMENT DEPTH*
3" Elbow	15"	6-1/16"	7"	4-3/4	3-3/8"
4" Elbow	15"	6-7/16"	7"	4-3/4	3-3/8"
6" Elbow	15"	7-9/16"	7"	4-3/4	3-3/8"
6" Spool	11-13/16"	-1-5/8"	9-3/16"	4-3/4	3-3/8"
8" Elbow	11"	3-7/16"	9-1/2"	4-3/4	3-3/8"
10" Elbow	19-11/16"	12-3/16"	9-1/2"	4-3/4	3-3/8"
12" Spool	14-11/16"	2-9/16"	24-1/2"	4-1	4-1/2"
20" Spool	26"	11-3/16"	26"	4-1	4-1/2"

*MINIMUM EMBEDMENT DEPTH IS FOR SUP-R-STUD ANCHOR BOLTS IN 2000PSI OR GREATER STRENGTH CONCRETE

MOUNTING THE NOZZLE ASSEMBLY IN YOUR PIT:

The Vaughan recirculation nozzle assembly is heavy and will require a crane to lift it into position over your pit. Wrapping appropriately rated lifting straps around the handles below the deck plate is the recommended method for lifting.

The outline dimension drawing prepared for your nozzle assembly shows anchor bolt locations, piping connection location, weight, and nozzle orientation.

Orient the deck plate of the nozzle assembly to make best use of the available nozzle rotation. In round pits, it is best if the assembly can be positioned so the nozzle can discharge parallel to the pit wall in both directions so that either clockwise or counterclockwise rotation can be established. In rectangular pits, position the unit near one corner with the nozzle capable of being aimed at the three remaining corners.

The exact details of your nozzle assembly, (i.e., parts breakdown, outline dimensions, and weight) are available from Vaughan Co. The illustration in this manual shows a typical arrangement.

INSTALLATION OF VALVE AND NOZZLE HANDLE ASSEMBLY

- Refer to outline drawing dimension for the location of the base elbow and valve body assembly. Mount the assembly to the bottom of the pit.
- Cut hole in slab per outline dimension drawing for handle extensions.
- Position the deck plate such that the handles are vertically directly over the valve body nozzle mating parts. Preferably, this is done with the aid of a plumb bob.
- If your handles are split couple them and tighten the set screws in the coupling with thread locker. There are also two 3/8" bolts that need to be installed to connect the deflector linkage.
- Loosen the set collars under the deck plate so that the handles can be adjusted and pushed down onto their mating components (valve and recirculation nozzle).
- Secure the deck plate to the floor slab.
- Slide set collar up against bottom of deck plate.
- Tighten set collar set screws to 130-inch pounds (11-foot pounds) with thread locker.

D. PIPING

As a rule in piping layout, avoid frictional losses by minimizing fittings and abrupt changes in direction and by choosing piping size carefully. Remember that when pumping sludges that this material has significantly higher friction losses than water, so larger diameter piping is often required.

▲CAUTION

Be sure that all piping connections are tightened and properly supported before operation of this pump.

If you are going uphill or going into a force main, or if there is more than one pump pumping into a common header, a check valve and isolation valve will be required on the discharge of the pump. *It is strongly recommended that you provide a pressure tap in the valve box or in the piping just above or out of the pit so that you can measure the actual operating conditions of the pump during startup. Also, if you are ever required to do any troubleshooting, this fitting will be required.* For pumping suspended solids, maintain at least 3-5 feet per second velocity in horizontal runs, and 8-10 feet per second in vertical runs. Otherwise, material can settle and plug the discharge line, particularly at elbows.

E. CONTROLS

If your installation is considered a hazardous location, be sure an electrician experienced in hazardous environment wiring and controls is involved with your installation.

Vaughan Submersible Chopper Pumps, because they cut and condition the material they pump, require positive motor protection with correctly sized breakers, starters, and overload protection. A Chopper Pump can jam and stall on material too tough to chop, such as steel rebar. Therefore, carefully chosen overload protection for your submersible motor is critical to avoid motor burnout. Note that nuisance tripping during chopping can occur if you do not have an adequately sized circuit breaker. The circuit breaker should never open during chopping, only during a short circuit. High current trip settings for Starters and VFD's should be set at 110% of motor nameplate full load current to prevent the current spikes from tripping out those devices while chopping.

Also, the submersible motors have two protective devices, the seal failure moisture probe, and the thermostatic switches. Both devices must be incorporated into the controls. The controls schematics presented in this manual show these items wired into the system. Also, please see the motor Installation and Operating Manual for more details on these devices.

Most submersible motors are suitable for use with VFD's or can be special ordered with "inverter duty" nameplates. Most motors (except for 2 pole/3600 rpm motors) are suitable for running at increased speeds to 150% of base speed or more, provided they stay within their current rating.

Selecting a motor with a base speed at the upper end of your operating range and slowing it down using a VFD to hit the low range results in lowest available torque and may not be recommended. *Note, when slowing a motor down below nameplate speed with a VFD it is very important to remember that available horsepower drops in direct proportion to speed reduction, so a 100 HP motor running at 30 Hz can only make 50 HP max at 30 Hz.*

Selecting a motor with a base speed at the lower end of your operating range and speeding it up using a VFD to hit the high range results in the highest available torque and is generally preferred for chopper pump applications. *When speeding a motor up above nameplate speed, available horsepower = nameplate horsepower.*

When driving chopper pump motors with a VFD, it is important that Constant Torque type VFD's be specified. Constant torque VFD's allow for maximum chopping torque at all speeds. (Variable Torque units have reduced torque and horsepower at reduced speeds) Minimum allowable VFD speed is dependent on system curve, and is the speed required to maintain minimum allowable flow per our published curves. Consult Vaughan Co. for assistance if needed.

Severe duty applications like septage receiving, screenings, beef processing, or any application with an external cutter often require oversizing the motor to get sufficient torque. Oversizing the motor has the added benefit of increasing rotational inertia to help carry the impeller through each chop.

F. SUBMERSIBLE MOTOR

Please read the submersible motor Installation and Operation Manual before operating this equipment. Please note that the submersible motor is designed to be cooled by the liquid in the pit. It can operate only 15 minutes in air before overheating and automatic opening of the internal thermostatic switches. For proper cooling and operation of this motor, it must be covered by liquid, or if it is uncovered, it must not operate for more than 15 minutes in air. Also, this motor is designed for explosion proof use in liquids at temperatures up to 104°F (40°C). In non-hazardous environments it can operate up to 149°F (65°C). This motor is not rated for use in liquid temperatures which exceed these limits.

The biggest cause of problems with submersible motors is electrical cable damage or damage to the cable cap assembly. Do not stretch the cable! And never lift the pump by the electrical cable! Otherwise, it will be damaged. Damage shows up as moisture probe or thermostatic switch failures (damage to the smaller of the two wires) or can result in a short of the main power cables.

▲WARNING

Baldor/Reliance submersible motors used on these pumps meet explosion proof requirements for hazardous environments. However, the guiderail system or may not meet the requirements for installation in a hazardous environment unless specifically ordered for this purpose. Introducing equipment not rated for a hazardous environment as defined by the National Electric Code can cause a dangerous explosion. Consult Vaughan Co. for help or advice.

SAMPLE SCHEMATIC FOR SUBMERSIBLE PUMP NON-EXPLOSION PROOF

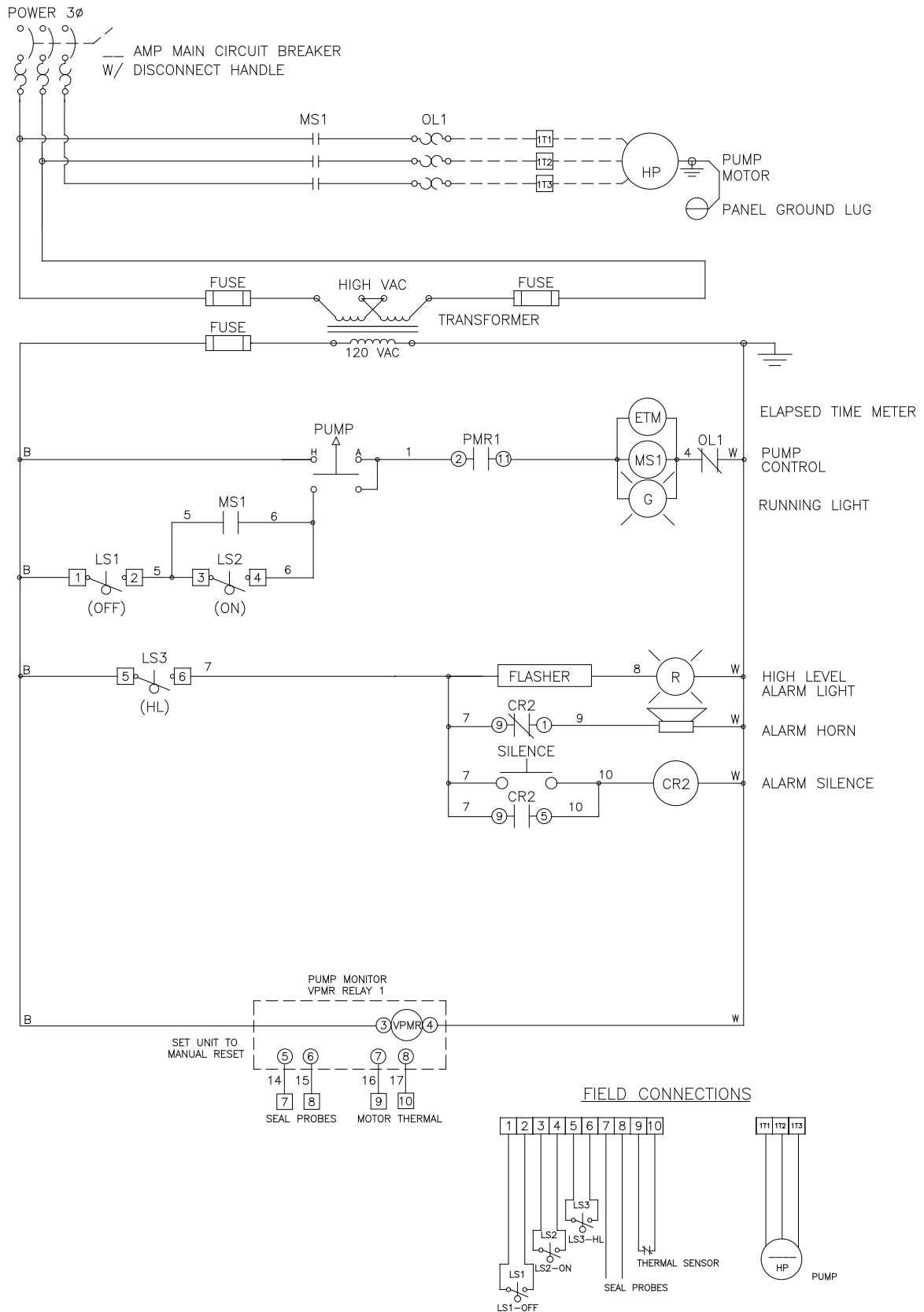

SECTION 4: PUMP STARTUP INSTRUCTIONS

NOTE: *Review all warnings in Section 1 of this manual.*

The submersible chopper pump cannot be properly started unless the pump is out of the pit. With the pump out of the pit, lying horizontally, take the following action:

⚠ WARNING

Stay clear of pump suction while performing pump rotation check. Serious injury or loss of limb is possible if clothing or hands are caught by the impeller.

1. Perform the rotation check. When checking pump rotation, first restrain the pump, and then at the control panel, hit the “ON” button, then the “OFF” button as fast as possible to merely “jog” the motor. If the impeller turns counterclockwise (as seen from the intake), then you are ready to start the pump. If the impeller turns clockwise, (wrong direction), open the circuit breakers to the motor panel while following your plant’s safety and lockout/tagout procedures for locking and tagging out breakers, and reverse any two leads to the motor starter in the control panel. Then close the breakers to the panel and recheck the pump rotation to be sure it is correct.

⚠ CAUTION

Restrain the pump during the rotation check to prevent possible damage to the pump or injury to personnel.

⚠ CAUTION

If the pump can run backwards for any significant length of time, the pump can be damaged.

2. Solid mounting of the pump onto the guiderail elbow helps keep vibrations minimized during operation of the pump. Anything you can do safely to make sure the pump is firmly seated onto the elbow will be helpful. If after startup the pump is vibrating, it may be helpful to lift the pump up and reseal it onto the elbow several times. And sometimes reseating the pump onto the elbow with the pump running is helpful. (Only do this with 1750 or 1170 RPM pumps, *never with a 3510 RPM pump.*)
3. The startup instructions are incorporated into the Startup and Certification Checklist. When the Startup and Certification Checklist is completed, you may start up the pump. Please send a copy of the completed checklist to: STARTUP@CHOPPERPUMPS.COM. We will verify that the pump and system are properly matched to protect your investment and our reputation. Vaughan Co. contact information is on the front of this manual.

NOTICE

Pump speeds and operating conditions must fall within the acceptable limits of the pump performance curve.



DATE: _____

Project Name: _____ Location: _____

Pump S/N: _____ Equipment ID/Tag#: _____

Startup Performed By: _____

Customer Contact Info _____

Contractor Contact Info _____

Engineer Contact Info _____

PRE-STARTUP CHECKLIST

- Was rotating equipment stored in a clean, dry heated area away from areas where it could be damaged from impact, smoke, dirt vibration, corrosive fumes, or liquids, or from condensation inside the motor or pump?

Yes _____ No _____

- If no, are you aware of any damage the equipment may have sustained?

- Was the shaft rotated 1-1/4 turn once each week?

Yes _____ No _____

- If no, how often was the shaft rotated?

- Was the exposed steel covered with a light layer of grease or Cosmoline to protect the equipment from corrosion?

Yes _____ No _____

- Was the bearing housing kept filled with ISO Grade 46 hydraulic oil (does not apply to SE Submersibles)?

N/A _____ Yes _____ No _____



DATE: _____

Project Name: _____ Location: _____

Pump S/N: _____ Equipment ID/Tag#: _____

Startup Performed By: _____

Customer Contact Info _____

Contractor Contact Info _____

Engineer Contact Info _____

VAUGHAN SE SERIES SUBMERSIBLE CHOPPER PUMP STARTUP AND CERTIFICATION CHECKLIST

Email completed form to: STARTUP@CHOPPERPUMPS.COM

- Pump Shaft turns freely by hand? Yes _____ No _____
- Pump is turning CCW as viewed from the intake? Yes _____ No _____
- Discharge valves are open? Yes _____ No _____
- Moisture Sensor Relay connected and tested to ensure proper function? Yes _____ No _____
- All piping joints are leaktight? Yes _____ No _____
- All piping attached to pump is being independently supported?
(not by the pump) Yes _____ No _____
- Flexible joint is attached to pump discharge? Yes _____ No _____
- If yes, is piping anchored between expansion joint and pump discharge,
Per H.I. Standards? Yes _____ No _____
- Has wet well been cleared of all construction debris? Yes _____ No _____
- Does Inflow splash down into sump? Yes _____ No _____
- Recirculation nozzles turn freely? N/A _____ Yes _____ No _____
- Deflector moves freely up and down? N/A _____ Yes _____ No _____

ELECTRICAL DATA

Motor Mfr: _____ HP: _____ RPM: _____

Nameplate Voltage: _____ Nameplate F.L. Amperage: _____

Operating Voltage: L1 – L2: _____ L2 – L3: _____ L1 – L3: _____

Operating Amperage: L1: _____ L2: _____ L3: _____

SYSTEM DATA

What type of material are you pumping? _____

Temperature (°F) _____ Specific Gravity _____ %Solids _____

Pipe Size (inch): _____ : Total equivalent length of pipe (feet) _____

Form V555, Rev. 2

ECN 5297, 5/25/23

Elevation change from water level to discharge point (feet) _____

Estimated Total Head (feet): _____ Design Flow (GPM): _____

PUMP OPERATING DATA

Pump Model: _____

Impeller Diameter: _____

Discharge Pressure (psig): **Pump Off (psi):** _____ **Pump On (psi):** _____

Dim "Z" (feet) _____ (distance from liquid level to pressure gauge)

Observed Pump flow (GPM): _____

Is pump running quietly? _____ Noisily? _____ Very Noisily? _____

NOTE: If pump is not running quietly, please contact us immediately for help. Severe vibration can damage the pump very quickly.

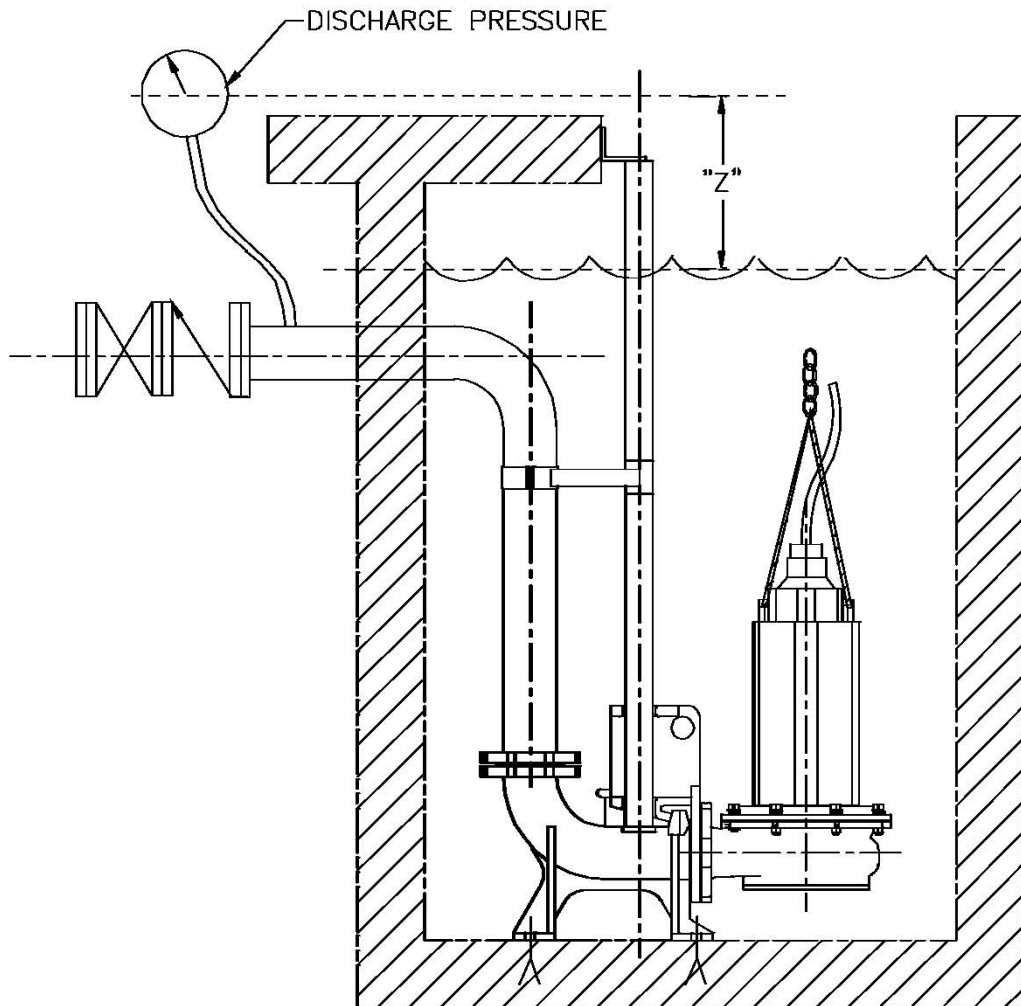

Form V555, Rev. 2

ECN 5297, 5/25/23

SECTION 5: NORMAL PUMP OPERATION

NOISE:

The Vaughan pumps which operate at either 1750 RPM or 1170 RPM are normally quiet running, and the major source of noise is the electric motor. Higher head pumps operating at 3510 RPM, however, will be noisier due to the nature of the pump design. Typically, noise level will be around 90-93 dbA in this pump. (However, mechanical vibrations should be minimal.) Also, there are times, particularly at startup, when the pit may be in bad condition, and an otherwise quiet running pump will be noisy, due to the large amount of chopping and conditioning work that the pump must do. In time, the pump noise should dissipate as most of the difficult material is broken up and homogenized.

VIBRATION:

Vibration, like noise, should be minimal in the pump unless the pump is doing heavy chopping. If a particularly tough rag, or nylon pantyhose gets caught in the pump, temporary dynamic imbalance and some flow blockage will occur until the rag is chopped up and cleared. These conditions will create vibration that is undesirable. But this condition is generally only temporary, and the chopping action of the pump normally clears the obstruction with time.

Please note that every effort has been made at the factory to ensure that this pump operates smoothly and without vibration. For example, all impellers are dynamically balanced after machining and heat treat to the ISO 1940/1 G6.3 balance standard. The pump shaft is very tightly held by the bearings so that there is virtually no shaft movement.

The most important action that you can take to eliminate vibration during operation is to make sure that you have a firm, solid, massive foundation to bolt the pump to during installation. Also, during repair, following the Vaughan Overhaul procedures and using Vaughan parts will give you the best chance of keeping your pump operating as smoothly as possible over time. And lastly, pumping liquid below 40° C or 65° C (see page 11) and operating the pump within the allowable head/ flow (solid line) portions of the performance curve will make sure that the pump does not cavitate and vibrate.

MOTOR OVERLOADS:

A motor overload is not part of normal operation but can happen more often in a chopper pump than in other types of “non-clog” pumps because of unpredictable chopping demands. If you find that the motor has tripped out on overload, have an electrician check operating amps when you restart the motor. Make sure that the motor is not pulling more than maximum allowable full load amps. ***Note especially that repeatedly resetting the motor overload devices and restarting the motor when it repeatedly trips out again is a guaranteed way to burn out the motor!*** Please pull the pump up out of the pit and see if something unchoppable is stuck in the pump before you ruin this expensive motor.

EXPECTED BENEFITS:

Most customers who install a Vaughan pump see several advantages:

1. Minimal pump attention required.
2. Minimal chances of pump plugging.
3. Minimal chances of loss of prime due to air binding.
4. Minimal problems downstream because material is preconditioned.
5. Minimal ancillary equipment required for grinding or comminuting or for mixing.

SECTION 6 SHUTDOWN INSTRUCTIONS

A. MANUAL SHUTDOWN:

In the manual mode of operation, a Vaughan pump is shut down by hitting the “OFF” button or turning the auto/man/off switch to the “OFF” position on the front panel of your control panel. If any repair or maintenance work is to be done on the pump, be sure to follow all the warnings at the beginning of this manual.

B. AUTOMATIC SHUTDOWN:

Automatic operation normally shuts the pump down for you, usually on low pit level. If the pump does not shutdown when the pit is pumped out, the pump may be shutdown manually, but you will want to troubleshoot your level control system to find out why the auto operation is not working properly.

If you are going to do any maintenance, adjustment or inspection on this pump or motor, be sure to follow all warnings in this manual, and your plant’s safety procedures. Be certain to turn off electrical power by opening and locking out the main panel breaker to isolate the pump. Since in the automatic mode, the pump could start without warning if not isolated.

⚠ WARNING

Lockout main panel breaker to prevent unintentional starting when working on this equipment

C. EMERGENCY SHUTDOWN:

In any kind of emergency when the pump needs to be shutdown, hit the manual “OFF” switch or pushbutton on the front of the pump control panel. If any work must be done on the pump or motor, open the main breaker on the pump control panel so that the pump cannot automatically restart when personnel are near the pump or motor.

SECTION 7: MAINTENANCE

A. ROUTINE MAINTENANCE

MONTHLY:

Check the amperage draw to the pump motor and compare to that measured at startup. Make sure that power draw does not exceed allowable amperage to the motor at full load.

ANNUALLY:

Remove pump from the pit and inspect for wear or damaged parts. Check for loose, corroded or worn hardware and tighten or replace, as necessary.

Isolate the pump electrically (open breakers) and remove pump from the pit. Inspect for suction blockage and check impeller clearance from cutter bar. It should be no greater than 0.025” maximum. The desired gap at the cutting edges is 0.015–0.025”.

If adjustment is necessary, the clearance can be adjusted externally by modifying the position of the rotating assembly. The entire rotating assembly, including the impeller, moves in and out of the casing to adjust the impeller-to-cutter bar gap. The cutter bar assembly bolts into the casing without shims.

TO ADJUST:

- a) Lay the pump on its side and secure it to prevent movement while working on the pump. Check cutter bar to impeller clearance to determine what adjustment is needed. The final impeller/cutter bar clearance will be 0.015” – 0.025”.
- b) Choose 3 of the adjusting sleeves (approximately equally spaced) to adjust the gap between the backplate and the casing flange. Remove the clamp bolts from the 5 remaining adjusters and using an Allen wrench back the 5 adjusters off.

c) Witness mark one point on each of the three adjusters you have chosen so you can track the adjustments you make and be sure that all the adjusters are all being rotated evenly. Note illustration at right.

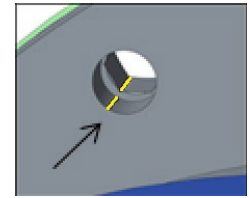

d) Adjust by removing one bolt at a time from the remaining 3 adjusters and moving adjusters in or out to gain the desired impeller to cutter bar clearance. By turning the adjusting sleeve in a clockwise direction, you are increasing the clearance between the cutter bar and impeller. Turning the adjuster one “point” is equal to about .010” movement. When clearance is achieved install clamp bolt and tighten. Repeat procedure with remaining two adjusting sleeves. Check impeller/cutter bar clearance and repeat adjustment procedure until the desired clearance is attained.

e) Once clearance is attained tighten the 5 remaining adjusting sleeves snug against the casing flange. (Note: overtightening can throw off clearance.) Install the clamp bolts and tighten. Recheck clearance.

f) Check for smooth shaft rotation by rotating the pump’s shaft by hand.

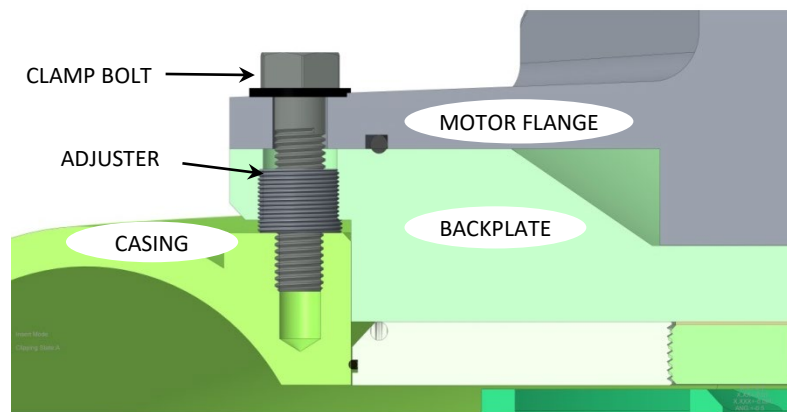

B. CORRECTIVE MAINTENANCE

Because overhaul of a Vaughan submersible pump is a major undertaking, the Overhaul Instruction is a separate procedure. Please do not try to overhaul or repair the pump without this important procedure and without the exploded assembly parts breakdown. The overhaul manual was sent to you by mail when your order for the pump was placed at the factory. If you do not have a copy of this manual, please call Vaughan Co. Engineering; we will make sure you get proper instructions overnight.

SECTION 9: TROUBLESHOOTING

The following table deals with pump and system problems but not with motor problems. The warranty for the submersible motors is covered by the motor manufacturer. Before contacting the manufacturer, please contact Vaughan Co. for advice.

Attached to this section is a troubleshooting chart that will help you get some idea of what symptoms could cause what problems. If you would like help, please call Vaughan Co. Engineering for troubleshooting help. We will be glad to help.

Note if your pump is equipped with a recirculation nozzle mid-stroke operation can cause debris to collect on the valve disk but simply cycling the valve should dislodge the debris.

		Short Life of Pumping Parts	Low Discharge Pressure	Loss or Contamination of Oil	Excessive Power Required	Abnormally High Vibration	Short Bearing or Seal Life	Pump Binding or Plugging	High Bearing Temp	Low Flow
SUCTION PROBLEMS	Insufficient NPSH		✓			✓	✓			✓
	Gas Binding of Pump (air trapped in eye of impeller)		✓			✓	✓			✓
	Vortexing in Pit at Inlet					✓				✓
	Intake Openings Blocked		✓			✓				✓
SYSTEM PROBLEMS	Pump Speed Too High or Impeller too Large	✓			✓	✓	✓			
	Pump Speed Too Low or Impeller too Small		✓			✓	✓			✓
	Fluid Excessively Hot	✓	✓			✓	✓			✓
	Pump Too Near Wall or Floor					✓	✓	✓		
	Pump Rotation Incorrect	✓	✓		✓	✓	✓	✓		✓
	System Head Too High					✓	✓			✓
	System Head Too Low	✓	✓		✓	✓	✓			
	Excessive Strain or Weight on Pump Flange					✓	✓			
	Pumped Fluid Abrasive or Corrosive	✓	✓					✓		✓
	Specific Gravity Higher than Expected				✓					✓
	Viscosity Higher than Expected				✓					✓
	Operation at Low Capacity					✓	✓			
	Improper Parallel Operation of Pumps	✓				✓	✓			✓
	Improper Series Operation of Pumps	✓			✓	✓	✓			
ELECTRICAL PROBLEMS	Loss of Phase				✓			✓		
	Low Voltage				✓			✓		
	Phase-to-Ground Leakage				✓					
MECHANICAL PROBLEM	Pump Discharge Blocked					✓				✓
	Foundation not Rigid					✓	✓			
	Disintegrator Tool Wrapped with Rags		✓			✓	✓			✓
	Worn Bearings				✓	✓			✓	
	Flooding of Oil Reservoir			✓						
	Overfilling of Oil Reservoir / Thermometer Effect			✓						
	Mechanical Seal Failure			✓						
	Bent Shaft					✓	✓			
	Cutter Bar Insert or Impeller Worn				✓			✓		
	Impeller Damaged or Loose on Shaft	✓	✓		✓	✓				✓
	Shaft Running Off Center					✓	✓			
	Lack of Lubrication				✓	✓	✓		✓	
	Improper Repair/Installation of Bearings			✓		✓	✓			
	Dirt in Bearings					✓	✓			
Impeller hitting internal cutter					✓					



VAUGHAN CO., INC. PRODUCT WARRANTY

Vaughan Company, Inc. (Vaughan Co.) warrants to the original purchaser/end user (Purchaser) all pumps and pump parts manufactured by Vaughan Co. to be free from defects in workmanship or material for a period of twelve (12) months from date of startup, not to exceed eighteen (18) months from the date of shipment from Vaughan Co. Startup data must be submitted to Vaughan Co. within 30 days of startup. If Purchaser fails to submit startup data within 30 days of startup, then Vaughan, in its sole discretion, may elect to void this warranty at any time. Purchaser must contact Vaughan Co. prior to commencing any repair attempts, or removing pump or parts from service. If Purchaser fails to contact Vaughan Co. prior to commencing any repair attempts or removing pumps or parts from service, then Vaughan, in its sole discretion, may elect to void this warranty at any time.

If during said warranty period, any pump or pump parts manufactured by Vaughan Co. prove to be defective in workmanship or material under normal use and service, and if such pump or pump parts are returned to Vaughan Co.'s factory at Montesano, WA, or to a Vaughan authorized Service Facility, as directed by Vaughan Co., transportation charges prepaid, and if the pump or pump parts are found to be defective in workmanship or material, they will be replaced or repaired by Vaughan Co. free of charge. Products repaired or replaced from the Vaughan Co. factory or a Vaughan authorized Service Facility under this warranty will be returned freight prepaid. Vaughan Co. shall not be responsible for the cost of pump or part removal and/or re-installation.

All warranty claims must be submitted in writing to Vaughan Co. not later than thirty (30) days after warranty breach occurrence. The original warranty length shall not be extended with respect to pumps or parts repaired or replaced by Vaughan Co. under this Warranty. This Warranty is voided as to pumps or parts repaired/replaced by other than Vaughan Co. or its duly authorized representatives.

Vaughan Co. shall not be liable for consequential damages of any kind, including, but not limited to, claims for property damage, personal injury, attorneys' fees, lost profits, loss of use, liability of Purchaser to customers, loss of goodwill, interest on money withheld by customers, damages related to third party claims, travel expenses, rented equipment, third party contractor's fees, or unauthorized repair service or parts. The Purchaser, by acceptance of delivery, assumes all liability for the consequences of the use or misuse of Vaughan Co. products by the Purchaser, its employees or others.

Equipment and accessories purchased by Vaughan Co. from outside sources which are incorporated into any Vaughan pump or any pump part are warranted only to the extent of and by the original manufacturer's warranty or guarantee, if any, which warranty, if appropriate, will be assigned by Vaughan Co. to the Purchaser. It is Purchaser's responsibility to consult the applicable product documentation for specific warranty information. Specific product documentation is available upon request. Any warranty shall be void if the total contract amount is not paid in full.

Vaughan Co. neither assumes, nor authorizes any person or company to assume for it, any other obligation in connection with the sale of its equipment with the exception of a valid Vaughan "Performance Guarantee" or "Extended Warranty," if applicable. Any other enlargement or modification of this warranty by a representative or other selling agent shall not be legally binding on Vaughan Co.

Warranty eligibility determination is at Vaughan Co.'s sole discretion.

Warranty Limitations:

This warranty shall not apply to any pump or pump part which has been subjected to or been damaged by any of the following non-exclusive list of causes:

- Misuse
- Abuse
- Accident
- Negligence
- Operated in the dashed portion of the published pump curves
- Used in a manner contrary to Vaughan's printed instructions
- Defective power supply
- Improper electrical protection
- Improper storage
- Faulty installation, maintenance, or repair
- Wear caused by pumping abrasive or corrosive fluids or by cavitation
- Dissatisfaction due to buyer's remorse
- Damages incurred during transportation
- Damages incurred during installation or maintenance

THIS IS VAUGHAN CO.'S SOLE WARRANTY AND IS IN LIEU OF ALL OTHER WARRANTIES, EXPRESSED OR IMPLIED, WHICH ARE HEREBY EXCLUDED INCLUDING IN PARTICULAR ALL WARRANTIES OF MERCHANTABILITY OR FITNESS FOR A PARTICULAR PURPOSE.

NOTES: _____

